

# Can Practice Overcome Age-Related Differences in the Psychological Refractory Period Effect?

François Maquestiaux  
UFR STAPS de l'Université Paris–Sud

Alan A. Hartley  
Scripps College

Jean Bertsch  
UFR STAPS de l'Université Paris–Sud

Can dual-task practice remove age-related differences in the psychological refractory period (PRP) effect? To answer this question, younger and older individuals practiced 7 blocks of a PRP design, in which Task 1 (T1) required a vocal response to an auditory stimulus and Task 2 (T2) required a manual response to a visual stimulus (Experiment 1). The results showed that practice did not reduce, but rather increased, age-related differences in PRP interference. Using the trained individuals, the introduction of a less complex new T1 (Experiment 2) or a less complex new T2 (Experiment 3) with the task previously practiced reduced the PRP interference but only in older adults. The authors propose that older adults suffer from a large task-switch cost that is more sensitive to task complexity than to the amount of practice.

Age-related differences in dual-task performance have been documented through many different dual-task paradigms; older adults commonly show greater dual-task interference than younger adults (for early reviews, see Hartley, 1992; Kieley, 1991; Kramer & Larish, 1996; for a later review, see Verhaeghen, Steitz, Sliwinski, & Cerella, 2003). One challenge for research on cognitive aging, therefore, is to determine what mechanisms are responsible for these age differences in performance. Another challenge is to determine whether and how these differences can be ameliorated. The current study aims to make progress on both of these issues by examining the effects of practice on age-related differences in dual-task interference.

The literature on the effects of practice on age-related differences in dual-task processing is quite limited (Kramer & Larish, 1996). Nonetheless, the recurrent finding is that older adults improve their ability to perform more than one task at once (e.g., Baron & Mattila, 1989; Greenwood & Parasuraman, 1991; Kramer, Larish, & Strayer, 1995; Kramer, Larish, Weber, & Bardell, 1999; McDowd, 1986; Salthouse & Somberg, 1982; Sit & Fisk, 1999; for a notable exception, see Rogers, Bertus, & Gilbert, 1994). In these procedures, at least one of the tasks is complex, involving a number of mental operations, so the precise nature of

the overlap between the two tasks may vary substantially from one trial to another. As a result, the specific sources of age differences and of improvements with practice in such procedures might be obscured by such aggregate measures (see Hartley & Little, 1999).

The alternative and more analytically tractable dual-task paradigm used in the experiments reported here is the psychological refractory period (PRP) procedure. This procedure involves presenting two successive stimuli, S1 and S2, separated by a controlled interval, called the stimulus onset asynchrony (SOA). SOAs typically range from ~50 ms to ~1,500 ms, resulting at the short end (i.e., 50 ms) in conditions with considerable temporal overlap between the two tasks and at the long end in conditions with little or no temporal overlap. (Conditions with complete temporal overlap—an SOA of 0—are sometimes used.) The individuals make a distinct response to each stimulus, performing Task 1 on S1 and Task 2 on S2. Because the stimuli are typically presented well above threshold, reaction time (RT) is the main dependent variable and the proportion of correct responses is a secondary dependent variable. The individuals are instructed to respond as fast and accurately as possible to each stimulus, often with emphasis on maintaining rapid responses to Task 1.

The typical finding in PRP experiments is that Task 1 RT (RT1) remains virtually unaffected by SOA, whereas Task 2 RT (RT2) increases by several hundreds of milliseconds from the longest SOA to the shortest SOA. This Task 2 slowing with decreasing SOA, first observed by Telford (1931), is called the PRP effect (for comprehensive reviews, see Lien & Proctor, 2002; Meyer & Kieras, 1997b; Pashler, 1994, 1998; Pashler & Johnston, 1998).

## Theories of the PRP Effect

There are two major theoretical accounts of dual-task performance: the central bottleneck model and models derived from the executive process–interactive control (EPIC) architecture.

---

François Maquestiaux, Jean Bertsch, UFR STAPS de l'Université Paris–Sud, Paris, France; Alan A. Hartley, Department of Psychology, Scripps College.

This research was supported by a doctoral grant from the Ministère de l'Éducation Nationale, de la Recherche et de la Technologie of France and National Institute on Aging Grant AG15–19195.

Correspondence concerning this article should be addressed to François Maquestiaux, who is now at Centre de Recherche, Institut Universitaire de Gériatrie de Montréal, 4565 Chemin Queen Mary, Montréal, Québec H3W1W5, Canada. E-mail: francois.maquestiaux@wanadoo.fr

### Central Bottleneck Model

Welford (1952), who noted that the PRP effect occurs even when two tasks do not obviously share input or output systems, proposed that the PRP effect is caused by an inability to perform central mental operations (e.g., response selection) on more than one task at a time. This proposal is known as the central bottleneck model. Figure 1 depicts this model, in which each task is decomposed into three successive stages: precentral stage (A), central stage (B), and postcentral stage (C). It is assumed that precentral and postcentral stages can be carried out in parallel. The central stages, however, are affected by a processing bottleneck: While Stage 1B is underway, Stage 2B must await completion of Stage 1B, resulting in a waiting time called the bottleneck delay. Pashler and Johnston (1989) formalized this central bottleneck model and derived several distinctive predictions regarding how different experimental manipulations of Task 1 and Task 2 stages should affect RT2, depending on whether the processing stage they lengthen occurs before, during, or after the bottleneck (Pashler, 1984; Schweickert, 1978, 1980; Schweickert & Townsend, 1989).

We summarize three signature predictions of the central bottleneck model: Task 1 carryover, Task 2 absorption, and Task 2 additivity predictions (for greater details, see Pashler & Johnston, 1989; Van Selst, Ruthruff, & Johnston, 1999). According to the Task 1 carryover prediction, increasing the duration of Task 1 processing stages up to and including the central stage should carry over onto Task 2 processing at short SOAs, when the central stage of Task 2 must be postponed until the central stage of Task 1 is completed, but not at long SOAs, when the central stage of Task 1 is completed before the central stage of Task 2 is ready to commence. That is, the effect of Task 1 difficulty on RT2 should be large at short SOAs (where carryover occurs) and small at long SOAs (where carryover should not occur). According to the Task 2 absorption prediction, the effects of increasing the duration of a Task 2 processing stage before the central stage will be absorbed into the Task 2 processing delay (often called cognitive slack) at short SOAs but not at long SOAs. That is, the effect of the manipulation of Task 2 precentral stages on RT2 should be small

at short SOAs (where absorption occurs) and large at long SOAs (where absorption should not occur). Finally, according to the Task 2 additivity prediction, increasing the duration of a Task 2 processing stage at or after the central stage will increase Task 2 processing time by a fixed amount whatever the SOA.

Several studies have verified the Task 1 carryover prediction (e.g., Karlin & Kestenbaum, 1968; Smith, 1969), Task 2 absorption prediction (e.g., De Jong, 1993; Pashler, 1984), and Task 2 additivity prediction (e.g., McCann & Johnston, 1992; Pashler & Johnston, 1989). Among the central stages subject to bottleneck that have been identified is response selection (Pashler, 1984).

### EPIC Architecture

Specific adaptive executive control models for dual-task performance derived from the EPIC architecture provide alternative accounts of the PRP effect (Meyer & Kieras, 1997a, 1997b, 1999; Meyer et al., 1995). This complex architecture assumes that according to the conditions (particularly instructions or experimental demands), the central stages of Task 1 and Task 2 can proceed either sequentially or in parallel, and it rejects any concept of a fixed, structural central bottleneck. Instead, bottlenecks or lockouts can be strategically placed precentrally (before Task 2 stimulus identification), centrally (before Task 2 response selection), or postcentrally (before Task 2 response generation). In a sense, the central bottleneck model is the special case of an EPIC architecture with a central bottleneck. Some empirical evidence supports this model of dual-task interference: With an easy Task 1, the effects of increasing Task 2 response-selection difficulty decrease as SOA decreases (Glass et al., 2000, Experiment 1). However, with a more difficult Task 1, Task 2 difficulty effects do not decrease as SOA decreases (Glass et al., 2000, Experiment 2). The decrease in Task 2 response-selection difficulty effects as SOA decreases is clearly inconsistent with the Task 2 additivity prediction of the central bottleneck model. Nevertheless, it is consistent with an EPIC architecture in which the bottleneck is inserted after Task 2 response selection, thus permitting the central stages for the two tasks to overlap temporally (see also Schumacher et al., 1999).

### Age-Related Changes in the PRP Effect

Several studies of age differences in dual-task performance have adopted the PRP procedure (Allen et al., 2002; Allen, Smith, Vires-Collins, & Sperry, 1998; Glass et al., 2000; Hartley, 2001; Hartley & Little, 1999) because of its advantages over alternative dual-task designs that have been used in previous studies (see Hartley & Little, 1999).

These studies have used a variety of combinations of input and output modalities, and most have obtained an age-related difference in the PRP effect (the only exceptions are with tasks belonging to the lexical domain; Allen et al., 2002). To account for overall age-related differences in the PRP effect, Hartley and Little (1999) proposed that a generalized age-related slowing factor, affecting all processing stages (perceptual, cognitive, and motor processes), might explain most of the observed age difference (Hartley & Little, 1999). On the basis of the claim that age differences are larger for central processing than for peripheral processing (Cerella, 1985), Allen et al. (1998) proposed a more specific explanation: that a specific decrement in response selection processes was responsible for the age-related differences. In

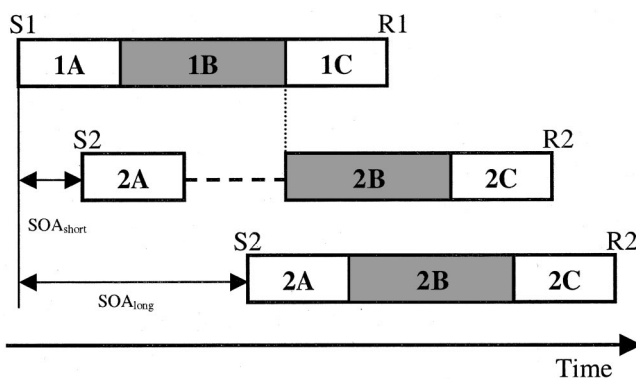

Figure 1. Central bottleneck model. R1 and R2 represent the Task 1 and Task 2 responses to the stimuli S1 and S2, separated by the stimulus onset asynchrony (SOA). The processing on each task is divided into three stages: A, B, and C. Stage B is the central stage. While Stage 1B is being carried out, Stage 2B must wait, resulting in a bottleneck delay (represented by the horizontal dashed line) at short SOA but not at long SOA.

addition to these more general factors, there may be some process-specific slowing, depending on the characteristics of the tasks used (Allen et al., 1998, 2002; Glass et al., 2000; Hartley, 2001; Hartley & Little, 1999; Meyer, Glass, Mueller, Seymour, & Kieras, 2001). In other words, there may be a mixture of process-specific and generalized age effects on processing speed (e.g., Allen et al., 2001; Fisk & Rogers, 1991; Fisk, Fisher, & Rogers, 1992; Sliwinski & Buschke, 1999; for a review, see Madden, 2001). For instance, there is evidence that older adults have a specific difficulty in organizing and executing two similar motor responses in rapid sequence (Hartley, 2001). In fitting EPIC architecture to their data, Glass et al. (2000) found that older adults had larger estimated parameter values for perceptual identification time, consistent with a process-specific age difference.

### *Effects of Practice on the PRP Effect*

In a series of experiments, Van Selst et al. (1999) and Ruthruff, Johnston, and Van Selst (2001) measured the PRP effect over an extended period of practice in younger adults. Unlike previous practice studies that had shown little reduction in PRP with practice and in which manual responses were required for both tasks (e.g., Bertelson & Tisseyre, 1969; Borger, 1963; Dutta & Walker, 1995; Karlin & Kestenbaum, 1968), Van Selst et al. and Ruthruff et al. attempted to minimize peripheral interference by using a design with two speeded-choice RT tasks in which Task 1 required a vocal response to a tone (but see Experiment 3 of Ruthruff et al.) and Task 2 required a manual keypress to an alphanumeric character. The PRP effect was dramatically reduced after 18 practice blocks, dropping from 353 ms in the first session to only 40 ms in the 18th session. Nevertheless, it remained robustly greater than 0. Moreover, these authors confirmed the Task 1 carryover prediction and the Task 2 absorption prediction of central bottleneck model even late in practice, suggesting that performance was still limited by a processing bottleneck.

To explain their results, Van Selst et al. (1999) proposed that practice reduces the duration of processing stages but does not eliminate the central bottleneck. They referred to this model as the bottleneck model with stage shortening (B-SS). They also proposed a more specific version, the bottleneck model with central stage shortening (B-CSS), with the restrictive assumption that practice shortens predominantly the duration of the central stages. This assumption seems like a reasonable first approximation: Not only do central stages constitute the novel aspect of the tasks, but also the stimuli were very discriminable and required simple overt responses. This assumption is also supported by several previous single-task studies using choice RT tasks (Fletcher & Rabbitt, 1978; Mowbray & Rhoades, 1959; Pashler & Baylis, 1991; Wolford, 1976).

According to the B-CSS model, practice should reduce the duration of the Task 1 central stage, which should, in turn, reduce the size of the PRP effect by a roughly equal amount. Consistent with this prediction, Van Selst et al. (1999) observed a one-to-one relationship over the first 18 blocks of practice between mean RT1 and the size of the PRP effect. Interestingly, the model predicts that reductions in the Task 2 central stage with practice should have no influence on the size of the PRP effect. To test this prediction, Ruthruff et al. (2001) transferred their participants to a design with the old Task 1 and a new Task 2. Even though

participants were unfamiliar with this new Task 2, PRP effects remained very small. Thus, their model correctly predicted that Task 2 practice was not the primary cause of reductions in the PRP effect.

Although Van Selst et al. (1999) and Ruthruff et al. (2001) found no evidence that participants could bypass the bottleneck, it is not yet clear whether this conclusion will generalize to other paradigms and other task combinations. Indeed, two studies using simultaneous dual-task presentation (rather than the variable SOA used in the PRP paradigm) appear to show that dual-task interference can be virtually eliminated after practice (Hazeltine, Teague, & Ivry, 2002; Schumacher et al., 2001). On the other hand, these studies both used relatively easy tasks with short RT1s, so that even a central bottleneck model would predict very little PRP effect (see Ruthruff, Johnston, Van Selst, Whitsell, & Remington, 2003). Thus, it is difficult to determine whether or not the bottleneck was bypassed in these studies.

Given that PRP interference increases with advancing age, it is only natural to then ask whether and how this problem can be ameliorated. Glass et al. (2000) observed a similar decrease in the PRP effect in younger and older adults (by 45 ms) from a second session of 960 trials to a third. Because data from the first session, with 320 trials of dual-task practice and 480 dual-task test trials, were not analyzed, the size of the PRP effect early in training, and therefore the total improvement resulting from practice, is unknown. Absent this information, the conclusion that the reduction in PRP with training is similar in younger and older adults requires further experimentation.

### *The Current Study: Goals and Predictions*

The main goal of the current study was to determine how practice affects age-related differences in PRP interference. More specifically, we asked whether the age-related difference in PRP interference could be overcome with practice.

We used a pair of tasks requiring a vocal response to the pitch of a tone (Task 1) and a manual response to a visually presented character (Task 2) because such a pairing facilitates substantial reduction in PRP interference with practice (Ruthruff et al., 2001; Van Selst et al., 1999). To facilitate comparisons between studies, we simply used the tasks used by Van Selst et al. (1999) in their practice study involving younger adults. In addition, such a vocal-manual design has previously been found to produce a large age-related difference in PRP interference at low practice levels (Allen et al., 1998).

In addition to our primary goal of asking whether quantitative age differences could be reduced, we also wished to explore whether practice has the same qualitative effect on older and younger adults. To this end, we examined the prediction of the B-CSS model, which is a specific version of the B-SS model, that declines in the PRP effect should roughly equal declines in RT1 across blocks.

If the greater PRP effect exhibited by older adults is mainly due to a generalized slowing factor affecting all processing stages with no age-related qualitative change in the processing bottleneck locus (i.e., it remains central), then two distinct sets of predictions follow. These two sets of predictions are both based on the assumptions that (a) initially all stages are slowed by the same factor in older adults (i.e., generalized slowing) and (b) younger

adults shorten only the central stage with practice, as argued by Van Selst et al. (1999). Each of the following sets of predictions, however, is based on different assumptions about which Task 1 and Task 2 stages are influenced by practice for older adults.

Suppose that the effect of practice is the same in older and younger adults, namely that practice reduces only the duration of central processing with no effect on the noncentral stages (1A, 1C, 2A, and 2C in Figure 1). A reduction of the duration of Stage 1B by  $k$  ms will reduce RT1 by the same  $k$  ms. Provided that there is a bottleneck delay on every trial, this reduction in the duration of Stage 1B will also reduce the bottleneck delay by  $k$  ms and thus reduce the PRP effect by  $k$  ms as well. Because the PRP effect and RT1 are both predicted to decline by the same  $k$  ms, the decline in the PRP effect with practice should track the decline in RT1 millisecond for millisecond. Empirically, a plot of the size of the PRP effect against RT1 across blocks of practice should show a linear relation with a slope of 1.0 both for younger and older adults. Such a pattern of results would support the B-CSS model in both age groups. In addition, the intercept for older adults should be smaller than that of younger adults. In other words, older adults should actually produce less PRP effect for a given RT1 value than do younger adults. To see why, consider the PRP equation, which expresses the PRP effect in terms of the durations of the component stages of Task 1 and Task 2 (Pashler & Johnston, 1989; Ruthruff et al., 2001):

$$\text{PRP effect} = 1A + 1B - 2A - \text{SOA}_{\text{short}} \quad (1)$$

Because  $\text{RT1} = 1A + 1B + 1C$ , it follows that  $1A + 1B$  can be expressed as  $\text{RT1} - 1C$ . Now, by replacing  $1A + 1B$  by  $\text{RT1} - 1C$  in the prior equation, the bottleneck model equation becomes

$$\text{PRP effect} = \text{RT1} - 1C - 2A - \text{SOA}_{\text{short}} \quad (2)$$

Because generalized slowing predicts a longer Stage 1C and Stage 2A for older adults, it also predicts a lower intercept in a plot of the PRP effect against RT1.

A second set of predictions follows if we suppose instead that in older adults practice reduces the duration of not only central stages but also noncentral stages of Task 1 (i.e., 1A and 1C) and of Task 2 (i.e., 2C and 2A). Decreases in the duration of Stage 1A will decrease both RT1 and the PRP effect by the same amount and, therefore, will preserve the aforementioned one-to-one PRP-RT1 relationship. Decreases in the duration of Stage 2C reduce RT2 by the same amount at all SOAs, so they would leave the size of the PRP effect unchanged. Because RT1 would also be unchanged, such decreases would have no effect on the PRP-RT1 relationship. In contrast, decreases in the duration of Stage 1C would cause the slope to be less than 1.0 because such a decrease would reduce RT1 without altering the amount of PRP interference. Decreases in the duration of Stage 2A would increase the PRP effect without influencing RT1, resulting in a PRP-RT1 slope of less than 1.0. Consequently, if practice shortens the durations of both central and noncentral stages in older adults, the ratio of PRP reduction to RT1 will fall below 1.0 (because of reductions in the durations of Stages 1C and 2A). Empirically, a plot of the size of the PRP effect against RT1 across blocks of practice should show a linear relation with a slope of less than 1. If we further assume that older adults perform these noncentral stages slower than younger adults, then the PRP-RT1 function for older adults should lie below that of

younger adults early in practice but then approach the PRP-RT1 function of younger adults without actually crossing over. Indeed, the intercept of Equation 2 (i.e.,  $-1C - 2A$ ), smaller in older adults than in younger adults, will produce a smaller PRP effect in older adults than in younger adults for a given RT1.

## Experiment 1

### Method

Twelve participants performed seven dual-task blocks spread over 4 days. The first day was devoted to familiarization with the apparatus, the tasks, and the first dual-task block. The last 3 days were devoted to dual-task practice, two blocks per day.

### Participants

Six younger adults ( $M = 23.5$  years,  $SD = 2.0$  years, range = 21–27 years, 1 woman and 5 men) and 6 older adults ( $M = 65.2$  years,  $SD = 3.5$  years, range = 62–70 years, 2 women and 4 men) participated in this experiment. Younger adults were recruited from the Université de Paris-Sud (Ile-de-France, France). Older adults were recruited from the local community of Evreux (Normandie, France). All participants were right-handed, volunteers, and highly motivated to participate in the study. Younger adults reported more years of education ( $M = 15.7$  years,  $SD = 0.5$ ) than older adults ( $M = 11.3$  years,  $SD = 3.7$ ),  $t(10) = 2.87$ ,  $p < .05$ . On a 10-point health rating scale (10 = *excellent health*), younger and older adults gave mean self-ratings of 8.0 ( $SD = 1.3$ ) and 8.2 ( $SD = 1.3$ ), respectively,  $t(10) = 0.22$ ,  $p = .83$ . Participants were screened for normal or corrected-to-normal vision and hearing using self-report. None of them reported any difficulties in discriminating the auditory and visual stimuli presented in the experiment.

### Stimuli

*Task 1.* The goal of Task 1 was to identify one of four possible tones presented for a duration of 200 ms. The two tones highest in pitch (2000 and 1800 Hz) were labeled as high tones, and the two tones lowest in pitch (400 and 200 Hz) were labeled as low tones. The pitches were chosen so that the most extreme tones were relatively easy to identify subjectively, whereas the two middle tones were relatively difficult to discriminate.

*Task 2.* Task 2 was to identify an alphanumeric character drawn from the set 1, 2, 3, 4, A, B, C, D, presented in Times New Roman font. The characters subtended approximately  $1.49^\circ$  vertically by  $1.04^\circ$  horizontally at a viewing distance of 46 cm. The background was white; the characters were black (high-contrast condition) or gray (low-contrast condition).

### Apparatus

Stimulus presentation and collection of responses were performed by a Dell Pentium III microcomputer controlled by E-Prime (version 1.1 Beta 1.0, Schneider, Eschman, & Zuccolotto, 2002), coupled with the Serial Response Box (Model #200a, Psychology Software Tools).

### Procedure

Participants responded to the pitch of the tone with a vocal response, either “high” or “low” (in French: “haut” or “bas”), into the headset microphone and responded to the character by pressing one of the four keys arranged horizontally on the response box using the fingers of the right hand. For half of the participants, the letters were mapped in alphabetic order onto the four response keys from left to right (a compatible mapping), whereas the numbers were mapped in a scrambled order (3, 1, 4, 2) onto the same four response keys (an incompatible mapping). For the other half

of the participants, numbers were mapped compatibly (1, 2, 3, 4) but letters were mapped incompatibly (C, A, D, B). Participants were instructed to respond as quickly and accurately as possible to each task while emphasizing the speed of Task 1 responses.

Each trial began with presentation of an asterisk in black for 500 ms, centered on the display. Then, a blank screen, varying randomly in duration from 100 ms to 250 ms (in steps of 50 ms), was introduced. Then the tone sounded for 200 ms. The SOA between the onset of the tone and the onset of the alphanumeric character was 50, 150, 250, 500, or 1,000 ms. The character appeared in the center of the screen and remained until a response was sensed or 4,000 ms had elapsed.

After each trial, if the participant failed to respond within 4,000 ms of the stimulus onset (either the tone or the character), a "too-slow" message (in French: "trop lent") was displayed for 500 ms. Another message, displayed for 300 ms, informed participants whether they made an erroneous or correct response on the two tasks. The intertrial interval was 1,000 ms.

At the beginning of the first block, participants completed 112 trials on Task 1 only and 112 trials on Task 2 only. Participants then performed 16 familiarization dual-task trials. These familiarization trials were followed by one block of 320 experimental dual-task trials during Day 1. The experimental trials were a random ordering of 2 trials each of the 160 trial types produced by a complete factorial cross of SOA (50, 150, 250, 500, and 1,000 ms), Task 1 difficulty (easier or harder tone discrimination), Task 2 contrast (black on white or gray on white), Task 2 mapping (compatible or incompatible), and Task 2 response finger (first through fourth finger). Participants were allowed to rest after the practice trials and after each block of 40 experimental trials. Each of 3 subsequent days began directly with 16 familiarization dual-task trials followed by a block of 320 experimental trials, an extended rest period, and another block of 320 experimental trials.

## Results

First, we describe different analyses of PRP interference across blocks of practice for both age groups. Second, we examine the predictions about the relationship between the PRP effect and RT1 derived from the bottleneck model extended to account for the effects of practice and aging. Third, we evaluate the carryover, absorption, and additivity predictions of the central bottleneck model both early and late in practice and for both older and younger adults. Fourth, we present analyses of Task 1 RTs as a function of SOA across blocks of practice. Fifth, we examine the proportion of correct answers on both Tasks 1 and 2.

Only dual-task trials with correct responses on both Task 1 and Task 2 and also with Task 1 or Task 2 latencies between 150 ms and 4,000 ms were included in the RT analysis. For the older and younger participants, 4.9% and 4.8%, respectively, of the dual-task trials were removed from the analysis.

### *The Effect of Practice on the PRP Effect*

The PRP effect was computed as the difference between RT2 at the 50-ms SOA and the 1,000-ms SOA.<sup>1</sup> Figure 2 shows the decline of the PRP effect in both age groups across the seven blocks of practice. First, note that the initial PRP effect (i.e., Block 1) was larger for older adults ( $M = 600$  ms,  $SD = 117$  ms) than for younger adults ( $M = 395$  ms,  $SD = 106$  ms),  $F(1, 10) = 10.15$ ,  $p < .01$ ,  $MSE = 12,438.7$ ,  $\eta^2 = .504$ .<sup>2</sup> This result replicates the findings of Allen et al. (1998), who also used a vocal-manual design.

An analysis of variance (ANOVA) was carried out on the PRP effect, with age group as a between-subjects variable and practice

(Blocks 1, 2, 3, 4, 5, 6 and 7) as a within-subjects variable. The PRP effect was overall greater in older ( $M = 486$  ms,  $SD = 123$  ms) versus younger ( $M = 210$  ms,  $SD = 127$  ms) adults,  $F(1, 10) = 30.26$ ,  $p < .01$ ,  $MSE = 52,876$ ,  $\eta^2 = .752$ . There was a substantial reduction in the PRP effect with practice,  $F(6, 60) = 26.97$ ,  $p < .01$ ,  $MSE = 3,291$ ,  $\eta^2 = .730$ ; the PRP effect declined from 497.5 ms in Block 1 to only 264.5 ms in Blocks 6 and 7 combined. This dramatic PRP reduction with practice replicates the results of Van Selst et al. (1999). Numerically, older adults showed a smaller reduction in the PRP effect ( $M = 192$  ms) across blocks than did younger adults ( $M = 274$  ms), although the overall ANOVA did not reveal a significant Practice  $\times$  Age Group interaction,  $F(6, 60) = 1.35$ ,  $p = .251$ ,  $MSE = 3,291$ ,  $\eta^2 = .119$ .

Because the initial PRP effect was considerably larger (by 205 ms) in older adults than in younger adults, we ran an analysis taking into account the initial point from which each age group started. To this end, an ANOVA was conducted on the change in PRP from Block 1 to Blocks 6–7 as a percentage of the PRP in Block 1. The percentage reduction in the PRP effect was significantly smaller for older (32%) than for younger (69%) adults,  $t(10) = 6.05$ ,  $p < .01$ .

One of the specific questions we set out to answer was whether practice can overcome the age-related differences in PRP interference. On the one hand, practiced older adults produced roughly the same level of PRP interference in their sixth block ( $M = 390$  ms,  $SD = 79$  ms) as younger adults produced in their first block ( $M = 395$  ms,  $SD = 106$  ms),  $t(10) = 0.09$ ,  $p = .93$ . In this sense, practice allowed older adults to overcome the age-related increase in PRP interference.<sup>3</sup> However, because older adults benefited less from practice than did younger adults, the effects of aging actually increased across blocks, from a 205-ms difference between older and younger adults in Block 1 to a 287-ms difference in Blocks 6–7.

### *The PRP Effect as a Function of RT1 Across Blocks 1–7*

Figure 3 presents the PRP effect as a function of RT1 at the longest SOA.<sup>4</sup> Each data point represents the average of all 6 participants (either younger or older) for one of the seven blocks. The linear fit was good, both for younger ( $r^2 = .943$ ) and older

<sup>1</sup> One might argue that the range of SOAs (50–1,000 ms) was not appropriate to measure the PRP effect in older adults. Because of general slowing, RT2 at the 1,000-ms SOA might still include a bottleneck delay in older adults, resulting in an underestimation of the true PRP effect. Nonetheless, a comparison of older adults' RT2 at the 1,000-ms SOA on Day 1 for the first block of dual-task practice ( $M = 1037$  ms,  $SD = 197$  ms) and in the 112 single trials on Task 2 only ( $M = 1077$  ms,  $SD = 247$  ms) showed no difference,  $t(5) = 0.63$ ,  $p = .56$ . This analysis demonstrated that the range of SOAs used was appropriate for measuring the PRP effect in older adults.

<sup>2</sup> The measure of effect size is partial  $\eta^2$ :  

$$\eta^2 = SS_{\text{effect}} / (SS_{\text{effect}} + SS_{\text{error}})$$

<sup>3</sup> This compensation for the age-related differences in PRP interference was accompanied by faster RT1 in older adults during Block 6 ( $M = 524$  ms,  $SD = 72$  ms) than in younger adults during Block 1 ( $M = 635$  ms,  $SD = 109$  ms), although the difference was only marginally significant,  $t(10) = 2.08$ ,  $p = .06$ .

<sup>4</sup> As shown in the Task 1 RTs section of Experiment 1, RT1 increased by 151 ms from the longest SOA to the shortest SOA, but only in older

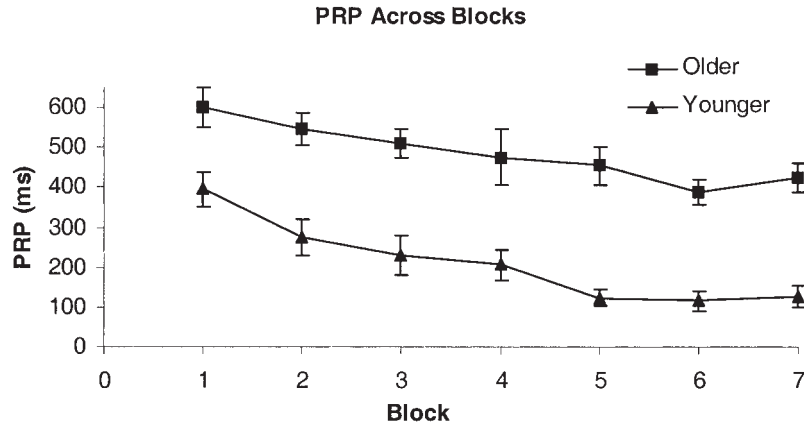

Figure 2. Psychological refractory period (PRP) effect as a function of blocks of practice in older adults and in younger adults (Experiment 1). Each line shows the mean PRP effect pooled across all participants (either older adults or younger adults):  $RT2_{SOA=50} - RT2_{SOA=1,000}$ , where RT2 = response time for Task 2 and SOA = stimulus onset asynchrony. Bars show standard errors.

( $r^2 = .863$ ) adults. (Linear fits were also good for individual participants; slopes were significantly different from 0 for 6 of 6 younger adults and 5 of 6 older adults). The B-CSS model predicts a linear relation between PRP effect and RT1 across blocks, with a slope of about 1.0. Inconsistent with this specific prediction, the slope was significantly less than 1.0 in younger (.832),  $t(10) = 2.63, p < .05$ , and older (.484) adults,  $t(10) = 6.24, p < .01$ . In older adults, in turn, the slope (.484) was significantly smaller than in younger adults,  $t(10) = 3.41, p < .01$ .

A slope of less than 1 supports a conclusion that practice shortens the duration of both central and noncentral stages. Because the slope is further below 1 in older adults than in younger adults, decreases in Stages 1C and 2A (i.e., those decreasing the ratio of PRP reduction to RT1) must be more pronounced in older adults. Following the model, we conclude that practice reduced the duration of noncentral stages more in older adults than in younger adults. Put another way, practice resulted in a relatively greater reduction of the duration of central stages for younger adults. This result is not consistent with a strong version of the B-CSS model (which predicted an exact 1:1 relationship between PRP effect and RT1 across sessions), but it is consistent with a weaker version of this model, in which practice reduces the duration of not only central stages but also noncentral stages (although possibly to a lesser extent).

A slope for older adults considerably less than 1.0 and well below that for younger adults might appear to be explained by a bottleneck model in which practice reduces the duration of both central (i.e., 1B and 2B) and noncentral (i.e., 1C and 2A) stages. Nevertheless, such a model predicts that the PRP-RT1 function for older adults should initially lie below that of younger adults and then approach the PRP-RT1 function of younger adults with in-

creasing practice. In complete disagreement with this prediction, the PRP-RT1 function for older adults actually lies well above that of younger adults. Later we discuss how these results might be explained.

Central Bottleneck Model Predictions

We performed an omnibus ANOVA on RT2, with age group as a between-subjects variable and practice (Blocks 1 and 2 vs. Blocks 6 and 7), Task 1 difficulty (easy tone or hard tone condition), SOA, Task 2 mapping (compatibility or incompatibility condition), and Task 2 contrast (high-contrast or low-contrast condition) as within-subjects variables.

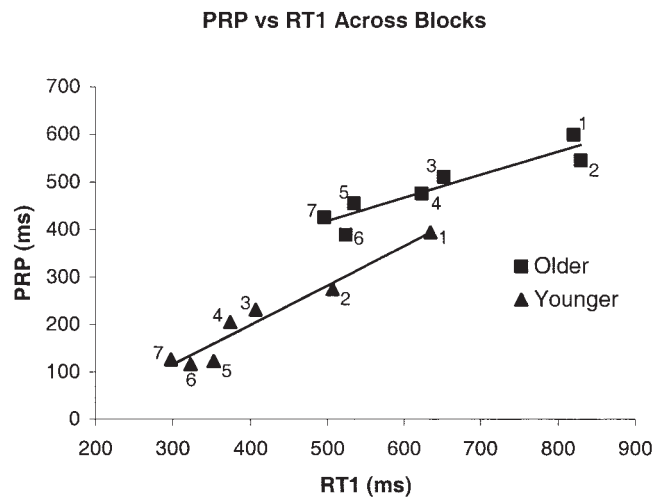

Figure 3. Task 1 response times (RT1) as a function of the psychological refractory period (PRP) effect for the seven blocks in older and younger adults.

$$PRP'_{older} = .484 (RT1) + 176.672, r^2 = .863.$$

$$PRP'_{younger} = .832 (RT1) - 133.865, r^2 = .943.$$

adults during the first block of practice, possibly because of a grouping strategy (Allen et al., 1998; Hartley & Little, 1999). To examine carefully the relation of the PRP effect as a function of RT1, we focused on RT1 at the longest SOA to remove any contamination from this increase at the shortest SOA.

*Task 1 carryover prediction.* Consistent with this prediction, the effect of Task 1 difficulty carried over onto RT2 at short SOAs (mean difference between hard and easy Task 1 = 148 ms) but not long SOAs (8 ms), evidenced by a significant interaction of Task 1 difficulty and SOA,  $F(4, 40) = 10.48$ ,  $p < .01$ ,  $MSE = 27,300$ ,  $\eta^2 = .512$ . The interaction among

age group, Task 1 difficulty, and SOA was marginally significant,  $F(4, 40) = 2.52$ ,  $p = .06$ ,  $MSE = 27,300$ ,  $\eta^2 = .256$ . Separate ANOVAs conducted in each age group, both early (Blocks 1–2) and late (Blocks 6–7) in practice, confirmed an overadditive interaction between Task 1 difficulty and SOA in both groups (see Figure 4A). The apparent exception was for

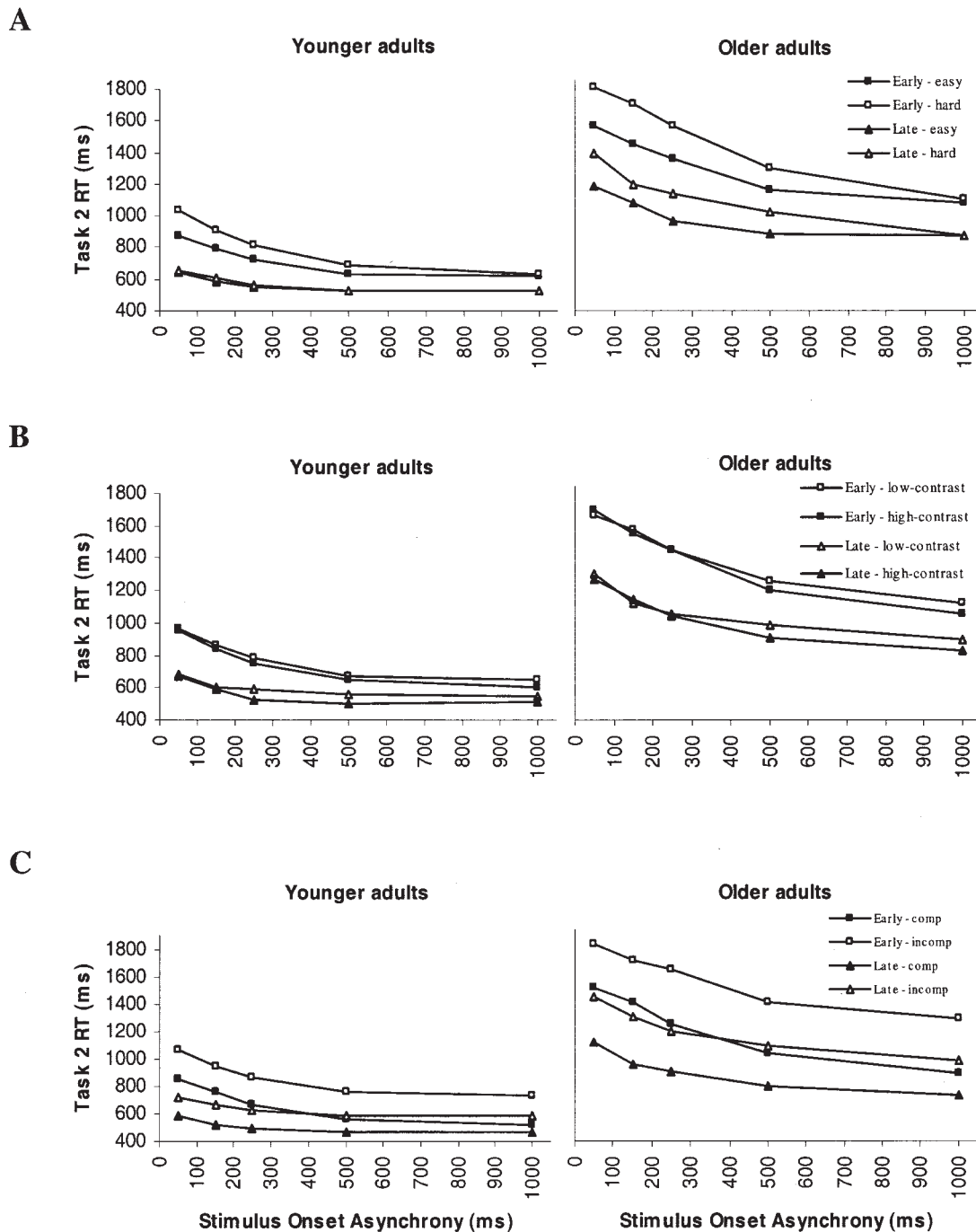

*Figure 4.* Task 2 reaction times (RT) in Experiment 1 as a function of practice (early and late) and Task 1–Task 2 stimulus onset asynchrony in both younger and older adults. A: The effect of Task 1 difficulty (easy tone or hard tone condition) on Task 2 RT. B: The effect of Task 2 contrast (high-contrast or low-contrast condition) on Task 2 RT. C: The effect of Task 2 mapping (compatible [comp] or incompatible [incomp] condition) on Task 2 RT.

younger adults late in practice, but this result can simply be attributed to the fact that their Task 1 difficulty effects had become negligible; the size of Task 1 difficulty effects on RT1 was 88 ms early in practice (Blocks 1–2) and shrank to only 7 ms late in practice (Blocks 6–7),  $t(5) = 3.40$ ,  $p < .02$ .

**Task 2 absorption prediction.** Consistent with this prediction, the effect of Task 2 stimulus contrast decreased from 53 ms at the longest SOA to 14 ms at the shortest SOA. This trend was marginally significant in the overall analysis (i.e., using all five SOAs),  $F(4, 40) = 2.21$ ,  $p = .09$ ,  $MSE = 18,861$ ,  $\eta^2 = .181$ , but was statistically significant in a contrast analysis including only the most extreme SOAs,  $F(1, 10) = 5.27$ ,  $p < .05$ ,  $MSE = 13,434$ ,  $\eta^2 = .345$ . Moreover, age group did not modify the underadditive interaction between Task 2 contrast and SOA observed in the contrast analysis,  $F(1, 10) = 3.51$ ,  $p = .09$ ,  $MSE = 13,434$ ,  $\eta^2 = .260$ . Separate ANOVAs were conducted both early (Blocks 1–2) and late (Blocks 6–7) in practice (see Figure 4B). Early in practice, there was an underadditive interaction between Task 2 stimulus contrast and SOA in a contrast analysis including only the most extreme SOAs,  $F(1, 10) = 5.22$ ,  $p < .05$ ,  $MSE = 21,306.4$ ,  $\eta^2 = .343$ . Age group did not modify this underadditive interaction,  $F(1, 10) = 1.38$ ,  $p = .27$ ,  $MSE = 21,306.4$ ,  $\eta^2 = .121$ . Late in practice, there was an underadditive interaction between Task 2 contrast and SOA in the overall analysis (i.e., using all five SOAs),  $F(4, 40) = 3.49$ ,  $p < .05$ ,  $MSE = 7,706$ ,  $\eta^2 = .259$ . Similarly, age group did not modify this underadditive interaction,  $F(4, 40) = 1.54$ ,  $p = .21$ ,  $MSE = 7,706$ ,  $\eta^2 = .134$ .

**Task 2 additivity prediction.** Mean RT2 was slower in the incompatible ( $M = 1,061$  ms) versus the compatible ( $M = 816$  ms) condition,  $F(1, 10) = 90.35$ ,  $p < .01$ ,  $MSE = 317,418$ ,  $\eta^2 = .900$ . Consistent with the Task 2 additivity prediction, the Task 2 mapping effect combined additively with SOA,  $F(4, 40) = .07$ ,  $p < .01$ ,  $MSE = 13,565.3$ ,  $\eta^2 = .007$ , estimated power = .062. Moreover, age group did not modify the additive effect of Task 2 mapping with SOA,  $F(4, 40) = .331$ ,  $p = .86$ ,  $MSE = 13,565.3$ ,  $\eta^2 = .032$ . Separate ANOVAs were conducted both early (Blocks 1–2) and late (blocks 6–7) in practice (see Figure 4C). Task 2 mapping and SOA did not interact: There was an additive effect of Task 2 mapping with SOA both early in practice,  $F(4, 40) = 1.03$ ,  $p = .40$ ,  $MSE = 20,402$ ,  $\eta^2 = .094$ , and late in practice,  $F(4, 40) = 1.31$ ,  $p = .30$ ,  $MSE = 8,875.6$ ,  $\eta^2 = .083$ . Age group did not modify these additive effects either early in practice,  $F(4, 40) = 1.085$ ,  $p = .38$ ,  $MSE = 20,402$ ,  $\eta^2 = .098$ , and late in practice,  $F(4, 40) = 0.76$ ,  $p = .56$ ,  $MSE = 8,875.6$ ,  $\eta^2 = .07$ .

**Caveat.** Both statistically and by inspection, there was no evidence for interactions of age groups with any of these effects. Nevertheless, with the small number of participants, the power of the design to have detected a significant effect was relatively low. Estimated power ranged from .22 to

.43 for the tests reported. Consequently, the results should be viewed with caution.

### Task 1 RTs

Figure 5 shows RT1 (along with RT2) as a function of SOA at two discrete points in time: the early block of practice (Block 1) and the late block of practice (Blocks 6 and 7 combined). We performed an ANOVA on RT1, with age group as a between-subjects variable and practice (Block 1 vs. Blocks 6–7) and SOA as within-subjects variables. There was a three-way interaction among age group, practice, and SOA,  $F(4, 40) = 4.47$ ,  $p < .05$ ,  $MSE = 812.25$ ,  $\eta^2 = .309$ , estimated power = .910. To decompose this interaction, separate ANOVAs were conducted in each age group. In younger adults, there was no main effect of SOA,  $F(4, 20) = 1.78$ ,  $p > .05$ ,  $MSE = 521.9$ ,  $\eta^2 = .263$ , estimated power = .446. There was no interaction between practice and SOA,  $F(4, 20) = 1.69$ ,  $p > .05$ ,  $MSE = 532.4$ ,  $\eta^2 = .253$ , estimated power = .426. In older adults, there was a significant two-way interaction between block of practice and SOA,  $F(4, 20) = 9.97$ ,  $p < .01$ ,  $MSE = 1,092$ ,  $\eta^2 = .666$ . During Block 1, there was a main effect of SOA,  $F(4, 20) = 11.09$ ,  $p < .01$ ,  $MSE = 2,335.5$ ,  $\eta^2 = .689$ . Post hoc comparisons using the Bonferroni procedure showed that RT1 was slower by 151 ms at the 50-ms SOA ( $M = 971$  ms,  $SD = 187$  ms) than at the 1,000-ms SOA ( $M = 820$  ms,  $SD = 72$  ms); no other comparison was significant. However, during Blocks 6–7, RT1 was unaffected by SOA,  $F(4, 20) = .56$ ,  $p = .69$ ,  $MSE = 362.6$ ,  $\eta^2 = .101$ , estimated power = .157. RT1 was 525 ms ( $SD = 113$  ms) at the 50-ms SOA and 510 ms ( $SD = 84$  ms) at the 1,000-ms SOA.

### Task 1 and Task 2 Proportion Correct (T1 and T2 PC)

We performed two ANOVAs, one on Task 2 proportion correct (T2 PC) and the other on Task 1 proportion correct (T1 PC), with age group as a between-subjects variable and block of practice and SOA as within-subject variables. The overall T2 PC started off at .94 in Block 1, decreased to .91 in Block 2, increased to .95 by Block 3, and remained similar until the end of practice (T2 PC =

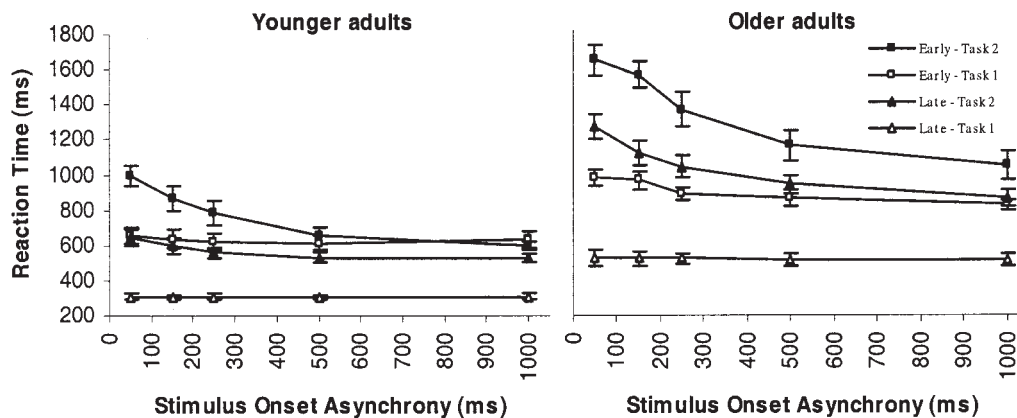

Figure 5. Task 1 and Task 2 reaction times in Experiment 1 as a function of Task 1–Task 2 stimulus onset asynchrony both in younger and older adults at two discrete points in time: the early block of practice (Block 1) and the late block of practice (Blocks 6 and 7 combined). Bars show standard errors.

.97 by Block 7),  $F(6, 60) = 7.77, p < .01, MSE = 24, \eta^2 = .437$ . T2 PC were .95 and .94 for older and younger participants, respectively,  $F(1, 10) = .36, p = .56, MSE = 392.5, \eta^2 = .035$ , estimated power = .085. Across these same blocks, the overall Task 1 proportion correct (T1 PC) remained similar,  $F(6, 60) = 0.51, p = .80, MSE = 27.8, \eta^2 = .049$ , estimated power = .193. T1 PC were .94 and .92 for older and younger participants, respectively,  $F(1, 10) = 1.06, p = .33, MSE = 396.6, \eta^2 = .096$ , estimated power = .154. Therefore, the reduction in the PRP effect with practice in both age groups was accompanied by modest changes in T2 PC and no changes in T1 PC. Nonetheless, lack of power might be responsible to the failure to find that the observed age differences both on T2 and T1 PCs were significant.

### Discussion

The results of Experiment 1 showed that practice can, in one sense, overcome the age-related differences in the PRP interference: Practiced older adults produced the same level of PRP interference in their sixth block as younger adults did in their first block. At the same time, the results demonstrated that practice reduces the size of the PRP effect but much more for younger adults (reduction of 69%) than for older adults (reduction of 32%). Indeed, the initial age-related difference in the PRP effect was further amplified across practice blocks: The effects of aging increased from 205 ms in Block 1 to 287 ms in Blocks 6–7. In older adults, RT1 increased at the 50-ms SOA only early in practice. (Such a result has been previously reported and has been interpreted as a sign of response grouping in older adults at low levels of practice; see Allen et al., 1998; Hartley & Little, 1999). This RT1 increase might have possibly increased RT2 at the 50-ms SOA (for an explanation of the positive correlations of RT1 and RT2 at short SOAs, see Pashler & Johnston, 1989), which, in turn, might have inflated the size of the PRP effect in older adults early in practice. This possibility, if true, further strengthens the result of an amplification of age-related differences in the PRP effect across practice blocks.

Another important finding was the confirmation of the three predictions derived from the bottleneck model both in younger and older adults and early and late in practice: (a) Task 1 difficulty effects generally carried over onto RT2 at short SOAs, (b) Task 2 contrast effects were absorbed at short SOAs, and (c) Task 2 mapping effects combined additively with SOA (cf. Glass et al., 2000, Experiment 2). This finding implies that the PRP effect observed both before and after practice in both age groups is consistent with a processing bottleneck or Task 2 lockout that prevents execution of the central mental operations of both tasks at the same time.

Moreover, the linear relation between the PRP effect and RT1 across blocks for younger adults with a slope less than 1.0 was consistent with a weak version of the B-CSS model, in which practice reduces not only the duration of central stages but also, although to a lesser extent, the duration of noncentral stages. In older adults, the slope fell significantly below that of younger adults. Consistent with the B-SS model, the flatness of the slope in older adults (.484) might have occurred because practice had substantial effects on the duration of both central and noncentral stages. However, this interpretation also predicts that the PRP-RT1 function early in practice should lie below that of younger adults

and then should approach the PRP-RT1 function of younger adults without actually crossing over. Contrary to this prediction, the PRP-RT1 function for older adults was well above that of younger adults (see Figure 3). Therefore, the B-SS model failed to provide a satisfactory account of practice effects on the PRP effect for older adults.

We propose a revision of the B-SS model. According to Equation 2, the intercept of the function relating the PRP effect and RT1 across blocks is  $-1C - 2A - SOA_{short}$ . Because of general slowing, it is reasonable to assume that the value of  $-1C - 2A$  would be lower (more negative) in older adults than in younger adults. In contrast, we actually observed a higher (more positive) intercept in older adults (177 ms) than in younger adults (–134 ms). To account for this surprising finding, we propose to add a stage (requiring time  $S$ ) to the prior equation. We assume that the stage is subsequent to response selection for Task 1 but that it precedes response selection for Task 2. Thus, the bottleneck model equation becomes

$$\text{PRP effect} = \text{RT1} - 1C - 2A + S - \text{SOA}_{short} \quad (3)$$

We could add the stage  $S$  only for older adults; however, it is more parsimonious to assume that it is present for both younger and older adults but assumes larger values for older adults.

Figure 6 depicts the central bottleneck model incorporating a parameter  $S$  in Task 2 processing sequence at short SOA but assuming  $S$  to be negligible at long SOA (Panel B) relative to the typical central bottleneck model (Panel A). The switching stage increases RT2 at short SOA but not at long SOA. Thus, it increases the PRP effect relative to the typical central bottleneck model.

There are precedents both in the central bottleneck model and in the EPIC architecture for postulating the existence of such a stage. Working in the central bottleneck framework, Ruthruff et al. (2001) had noted that some variable time  $S$  might be required for participants to switch from performing Stage 1B to performing Stage 2B, but they did not incorporate this parameter in the traditional bottleneck model equation because most PRP phenomena (at least for younger adults) could be explained without it (see also Pashler, 1994; Pashler & Johnston, 1989). Furthermore, De Jong (1995) argued that younger adults prepare for both Task 1 and the switch to Task 2 in advance of the trial, which would reduce or eliminate any switch time after Task 1 response selection (see also Lien, Schweickert, & Proctor, 2003).

EPIC architecture models with a strategic response delay imposed on Task 2 assume the existence of up to three executive processes between the completion of Task 1 response selection and the inception of Task 2 response selection (Glass et al., 2000; Meyer & Kieras, 1997a): delay before unlocking of Task 2 processing, Task 2 unlocking, and temporary suspension of Task 2 while processing is reset from deferred mode (processing in the background of Task 1) to immediate mode (processing in the foreground). Collectively, these could be characterized as Task 2 unlocking delay. The EPIC parameter estimates reported by Glass et al. (2000) gave higher values of the unlocking delay for older adults than for younger adults.

The question is how to characterize this additional stage. Expanding on the speculations of Hartley and Little (1999), we propose that the operations carried out during this stage include activating or instantiating the rules that map Task 2 stimuli onto responses. It may be that the rules must be moved back into working memory or that the rules remain in working memory

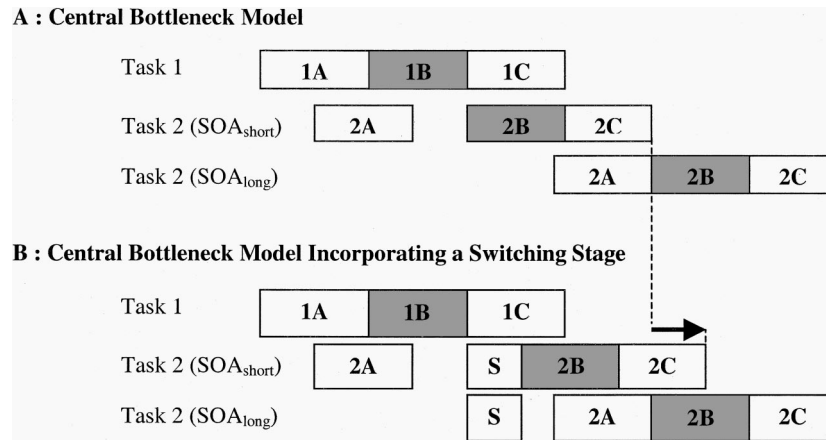

*Figure 6.* The central bottleneck model elaborated to include a switching parameter (*S*). A: When both Task 1 and Task 2 can be fully prepared before the beginning of the trial, no switching parameter is required during Task 2 processing sequence. B: When Task 2 response preparation cannot be (fully) prepared before the beginning of the trial, it is instantiated in Task 2 processing only after Stage 1B has been completed at short stimulus onset asynchrony (SOA) but before the beginning of Stage 2A at long SOA.

throughout the task but that the links between the abstract code for the stimulus and particular effector actions must be reestablished. The important point is that this stage either is not always needed or, more parsimoniously, is much shorter under certain circumstances than others. One such circumstance is an older individual who may have more limited capabilities for holding response mappings in working memory or for whom maintaining two sets of linkages between stimulus codes and effector actions may cause more interference. We hypothesize, then, that more complex mapping rules should exaggerate age differences in PRP interference and, conversely, that simpler mapping rules should reduce age differences. Contrary to the central bottleneck model, this should be true for the mapping rules for both Task 1 and Task 2. The Task 1 carryover prediction implies that reducing the complexity of Task 1 should reduce PRP interference, but the Task 2 additivity prediction implies that reducing the complexity of Task 2 should leave interference unaffected. Our hypothesis is not inconsistent with the EPIC architecture; our predicted result for simpler mapping rules would be seen as a smaller parameter estimate for Task 2 unlocking time. Our hypothesis adds a theoretically motivated explanation for such a result.

It is important to understand that our proposal addresses not the difficulty of either task but rather the complexity of the response mappings. For example, a task that required discrimination of an 800-Hz tone and a 1200-Hz tone would be more difficult and would produce longer RTs than a task that required a discrimination between a 400-Hz tone and a 1600-Hz tone, but the response mapping rules would be equally complex.

In Experiment 1 the tasks were more complex than the tasks typically used in PRP studies. With eight possible stimuli (comprising two distinct sets) and four possible responses on Task 2, it seems plausible that older adults could not complete the complex Task 2 response preparation before the beginning of the trial. We propose that they put in place or completed putting in place the response mapping rules for Task 2 only after Task 1 response selection was completed. Although younger adults may evidence a

similar process early in practice, we assume that late in practice they could either put the response mappings for both tasks in place before the trial started or put the mapping rules for Task 2 in place after response selection for Task 1 was complete but did so much more quickly. The operation of putting the Task 2 response mapping in place would slow RT<sub>2</sub> at short SOAs but not at long SOAs (where the operation can be completed during the SOA period).

Experiments 2 and 3 were designed to test the hypothesis that introducing less complex response mappings for Task 1 or Task 2 would reduce PRP interference but mainly in older adults.

#### Experiment 2: Transfer to a Design With New Task 1 and Old Task 2

The 6 practiced younger adults and 5 of the 6 practiced older adults (1 older adult opted not to continue) from Experiment 1 participated in Experiment 2, in which a new Task 1 with a less complex response mapping was paired with old Task 2 (from Experiment 1). We reasoned that the use of a less complex Task 1 would, particularly for older adults, either reduce the time needed to put the Task 2 response mapping rules in place after Task 1 response selection was completed or facilitate the instantiation of Task 2 mapping rules in advance of the trial. To this end, we adopted the tasks used by Ruthruff et al. (2001, Experiment 1), with minor changes. The new Task 1 required participants to compare a pair of tones and say whether the tones were same or different in pitch. The production rules for response selection were as follows:

```
IF    MATCH? (TONE 1, TONE 2)
THEN SEND-TO-MOTOR (VOCAL PERFORM ["SAME"])
ELSE  SEND-TO-MOTOR (VOCAL PERFORM ["DIFFERENT"])
```

For old Task 1, requiring participants to identify the pitch of one of four possible tones and say whether it was high or low in pitch, the production rules would have been as follows:

```

IF      MATCH (TONE, RECALL-FROM-MEMORY [2000 Hz])
THEN   SEND-TO-MOTOR (VOCAL PERFORM ["HIGH"])
ELSEIF MATCH (TONE, RECALL-FROM-MEMORY [1800 Hz])
THEN   SEND-TO-MOTOR (VOCAL PERFORM ["HIGH"])
ELSEIF MATCH (TONE, RECALL-FROM-MEMORY [400 Hz])
THEN   SEND-TO-MOTOR (VOCAL PERFORM ["LOW"])
ELSEIF MATCH (TONE, RECALL-FROM-MEMORY [200 Hz])
THEN   SEND-TO-MOTOR (VOCAL PERFORM ["LOW"])

```

The rules for new Task 1 are arguably less complex than those for old Task 1. Nevertheless, because the new task involves comparing two freshly heard tones whereas the old task involves matching a tone to one of four recalled tones, we do not know whether the task is more or less difficult (i.e., will have longer or shorter RTs).

The new Task 1 either might make it easier to put the Task 2 rules in place after Task 1 response selection is complete or might be sufficiently simple to allow Task 2 response preparation to be completed before the beginning of the trial. If so, the PRP effect for older adults in Experiment 2 should be smaller than for the late blocks of Experiment 1. On the other hand, for younger adults, arguing from the weak version of the B-CSS model, introducing a new Task 1 should affect PRP in Experiment 2 only to the extent that it shortened or lengthened RT1.

### Method

#### Participants

This experiment included the same participants as in Experiment 1 less 1 older adult, thus slightly modifying the characteristics of older age group. The 5 older adults (1 woman and 4 men;  $M = 64.4$  years,  $SD = 3.3$  years, range = 62–70 years) reported fewer years of education ( $M = 11.8$  years,  $SD = 3.9$ ) than younger adults,  $t(9) = 2.43$ ,  $p < .05$ . Older adults gave a mean self-rating of 8.4 ( $SD = 1.3$ ), similar to that of younger adults,  $t(9) = 0.51$ ,  $p = .62$ .

#### Stimuli

The stimulus for Task 1 was a pair of tones presented for 84 ms each (interstimulus interval = 150 ms). The frequency of the first tone was selected at random from the set of 1200, 1250, 1300, 1350, 1400, 1450, 1500, 1550, and 1600 Hz. On half of the trials, the second tone was identical in pitch to the first tone (same trials). On the other half, the frequency of the second tone was either 0.6 or 1.4 times the frequency of the first tone (different trials). RT1 and SOA were measured relative to the onset of the second tone. The stimulus set for Task 2 was the same as in Experiment 1.

#### Procedure

Except for the introduction of a new Task 1 and where noted, the dual-task procedure was similar to that of Experiment 1.

Participants responded to the pair of tones with a vocal response, either "same" (in French: "même") or "different" (in French: "différent"), into the headset microphone. For Task 2, the mapping of alphanumeric characters onto response keys assigned to each participant in Experiment 1 was not modified.

Participants began with 32 practice trials on Task 1 only and 32 practice trials on Task 2 only. Then participants performed 16 practice dual-task

trials, which were followed by one block of 320 experimental dual-task trials.

### Results

The central results are comparisons between the late Blocks 6–7 of Experiment 1 and Experiment 2. Figure 7 shows the mean PRP effect, RT2, and RT1 in both age groups for Blocks 1 and 6–7 of Experiment 1 and for Experiment 2. The RT2 and RT1 data in Figure 7 come from the long SOA condition only (i.e., 1,000 ms) to show the changes in baseline Task 2 and Task 1 performance (for which dual-task interference should be minimal).

Before analyzing the size of the PRP effect, it is important to determine first whether Task 2 performance remained unaffected by the introduction of a new Task 1 and then to compare performance between new Task 1 and old Task 1. For each of the three analyses on mean RT2, mean RT1, and mean PRP, we conducted an ANOVA, with age group as a between-subjects variable and experiment (Blocks 6–7 of Experiment 1 vs. Experiment 2) as a within-subject variable.

#### RT2: Late Blocks of Experiment 1 Versus Experiment 2

For older adults, mean RT2 at the longest SOA was 838 ms ( $SD = 129$  ms) in Blocks 6–7 of Experiment 1 and 855 ms ( $SD = 157$  ms) in Experiment 2. For younger adults, mean RT2 at the longest SOA was 518 ms ( $SD = 60$  ms) in Blocks 6–7 of Experiment 1 and 533 ms ( $SD = 62$  ms) in Experiment 2. Although there was a main effect of age group,  $F(1, 9) = 27.36$ ,  $p < .01$ ,  $MSE = 20,519.6$ ,  $\eta^2 = .752$ , neither the main effect of experiment,  $F(1, 9) = .71$ ,  $p = .42$ ,  $MSE = 1,927.2$ , nor the Age Group  $\times$  Experiment interaction,  $F(1, 9) = .004$ ,  $p = .95$ ,  $MSE = 1,927.2$ , was significant. Consequently, Task 2 learning transferred well in each age group despite being paired with a new Task 1.

#### RT1: Late Blocks of Experiment 1 Versus Experiment 2

For older adults, mean RT1 at the longest SOA was 495 ms ( $SD = 86$  ms) in Blocks 6–7 of Experiment 1 and 496 ms ( $SD = 55$  ms) in Experiment 2. For younger adults, mean RT1 at the longest SOA was 310 ms ( $SD = 38$  ms) in Blocks 6–7 of Experiment 1 and 400 ms ( $SD = 84$  ms) in Experiment 2. Although there was a main effect of age group,  $F(1, 9) = 21.18$ ,  $p < .01$ ,  $MSE = 5,098.5$ ,  $\eta^2 = .702$ , neither the main effect of experiment,  $F(1, 9) = 2.61$ ,  $p = .14$ ,  $MSE = 4,255.6$ ,  $\eta^2 = .225$ , nor the Age Group  $\times$  Experiment interaction,  $F(1, 9) = 2.51$ ,  $p = .15$ ,  $MSE = 4,255.6$ ,  $\eta^2 = .218$ , was significant. However, there is a trend for younger adults to have suffered more from the transfer than the older adults: The new mean RT1 was numerically longer by 90 ms than the old mean RT1 in younger adults, but by only 1 ms in older adults.

#### PRP Effect: Late Blocks of Experiment 1 Versus Experiment 2

The PRP effect was overall greater in older adults ( $M = 371$  ms,  $SD = 66$  ms) than in younger adults ( $M = 128$  ms,  $SD = 63$  ms),  $F(1, 9) = 38.79$ ,  $p < .01$ ,  $MSE = 8,312$ ,  $\eta^2 = .812$ , and in Blocks 6–7 of Experiment 1 ( $M = 260$  ms,  $SD = 172$  ms) than in

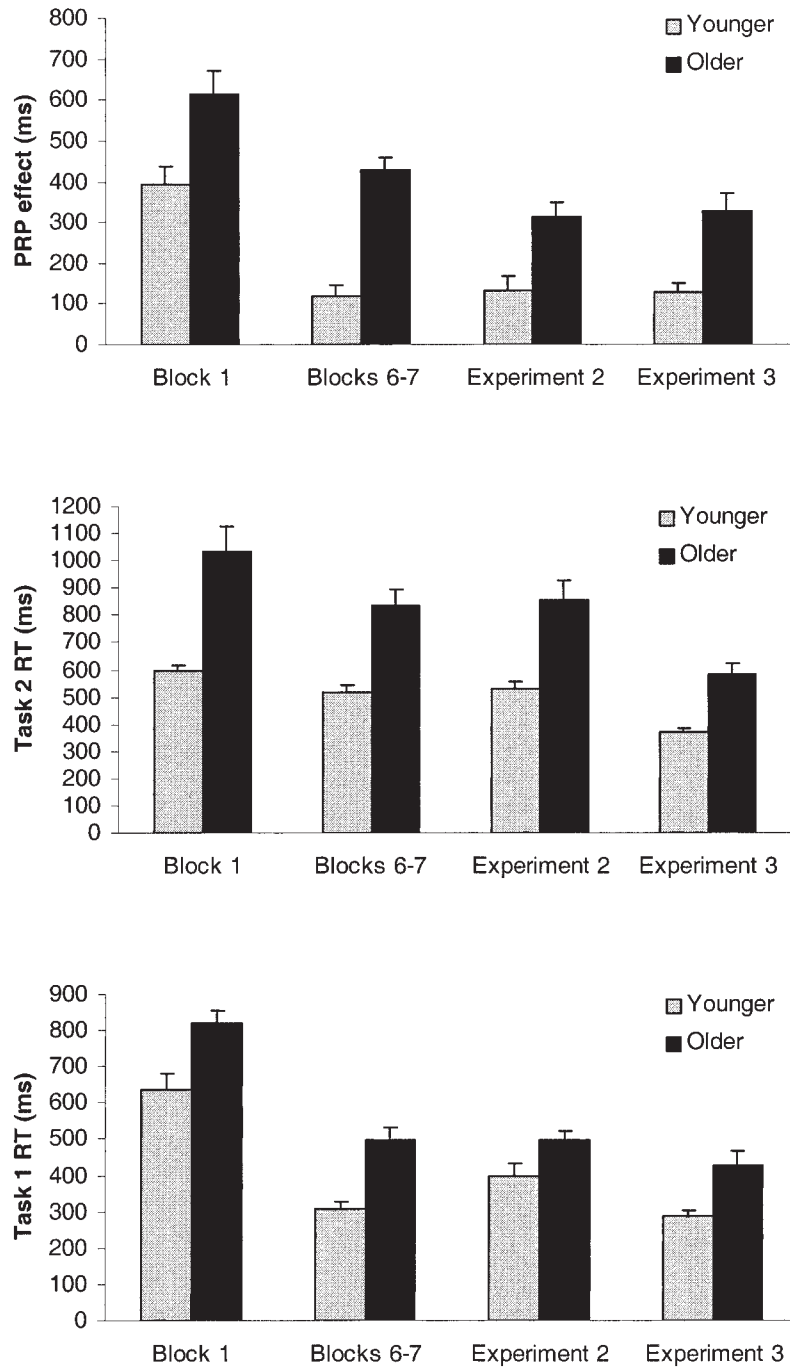

Figure 7. The psychological refractory period (PRP) effect (top), mean Task 2 reaction time (RT) at the 1,000-ms stimulus onset asynchrony (SOA; middle), and mean Task 1 RT at the 1,000-ms SOA (bottom) in Blocks 1 and 6–7 of Experiment 1 and Experiments 2 (new Task 1 and old Task 2) and 3 (old Task 1 and new Task 2) in younger and older adults. Bars show standard errors.

Experiment 2 ( $M = 216$  ms,  $SD = 119$  ms),  $F(1, 9) = 5.99$ ,  $p < .05$ ,  $MSE = 2,235.4$ ,  $\eta^2 = .400$ . The two-way Age Group  $\times$  Experiment interaction was significant,  $F(1, 9) = 9.53$ ,  $p < .05$ ,  $MSE = 2,235.4$ ,  $\eta^2 = .514$ . For older adults, the PRP effect declined significantly (by 112 ms) from Blocks 6–7 of Experiment 1 ( $M = 427$  ms,  $SD = 76$  ms) to Experiment 2 ( $M = 315$  ms,  $SD =$

77 ms),  $F(1, 4) = 10.49$ ,  $p < .05$ ,  $MSE = 2,992.4$ ,  $\eta^2 = .724$ . For younger adults, however, the PRP effect actually increased slightly (by 13 ms, although the difference was not statistically significant) from Blocks 6–7 of Experiment 1 ( $M = 121$  ms,  $SD = 59$  ms) to Experiment 2 ( $M = 134$  ms,  $SD = 78$  ms),  $F(1, 5) = 0.31$ ,  $p = .60$ ,  $MSE = 1,629.8$ ,  $\eta^2 = .058$ .

### Task 1 RTs

An omnibus ANOVA was performed on RT1 observed in Experiment 2, with age group as a between-subjects variable and Task 1 difficulty, SOA, Task 2 mapping, and Task 2 contrast as within-subjects variables. Mean RT1 was greater in older adults ( $M = 513$  ms,  $SD = 54$  ms) than in younger adults ( $M = 397$  ms,  $SD = 83$  ms),  $F(1, 9) = 7.09$ ,  $p < .05$ ,  $MSE = 206,287.1$ ,  $\eta^2 = .440$ . No other effect was significant. In particular, RT1 remained unaffected by SOA,  $F(4, 36) = 1.94$ ,  $p = .12$ ,  $MSE = 4,002.7$ ,  $\eta^2 = .178$ . Moreover, the Age Group  $\times$  SOA interaction was not significant,  $F(4, 36) = 1.34$ ,  $p = .27$ ,  $MSE = 4,002.7$ ,  $\eta^2 = .130$ .

### Task 1 and Task 2 Proportion Correct (T1 and T2 PC)

We performed two ANOVAs, one on Task 1 proportion correct (T1 PC) and the other on Task 2 proportion correct (T2 PC), with age group as a between-subjects variable and SOA as a within-subject variable. There were no significant main effects or interactions in either analysis. T1 PC were .92 and .97 for younger and older participants, respectively,  $F(1, 9) = 1.14$ ,  $p = .31$ ,  $\eta^2 = .113$ ; and T2 PC were .93 and .97 for younger and older participants, respectively,  $F(1, 9) = 2.71$ ,  $p = .13$ ,  $\eta^2 = .232$ . Again, it is important to acknowledge that the power of the tests was low so T1 and T2 PCs might be greater in older adults than in younger adults but the difference was not detected as significant. Accuracy was somewhat greater for older adults in Experiment 2 than in Experiment 1. Nevertheless, RTs were not longer in Experiment 2, so there is no evidence of a shift in speed-accuracy criteria.

### Discussion

The results of Experiment 2 were straightforward. The introduction of new Task 1, chosen to require less complex response mappings than old Task 1, reduced the PRP effect in older adults but not in younger adults. Consequently, the results are consistent with the hypothesis that there was an extra stage after Task 1 response selection and before Task 2 response selection and that this stage was noticeably longer when the response mapping was more complex (Experiment 1) but not when it was less complex (Experiment 2). The stage either was only present for older adults or was noticeably longer for older adults than for younger adults. For younger adults, the introduction of new Task 1 had little effect on the magnitude of PRP interference. We speculate that younger adults were able to prepare for both Task 1 and Task 2 in advance of the trial and thus did not need an extra task-switching stage before Task 2 response selection regardless of whether the Task 1 response mapping was more (Experiment 1) or less (Experiment 2) complex.

### Experiment 3: Transfer to a Design With Old Task 1 and New Task 2

The same participants from Experiment 2 were used in Experiment 3, in which old Task 1 from Experiment 1 was paired with a new Task 2. The main goal of Experiment 3 was to determine whether, for older adults, introducing a new Task 2 with lower response selection demands would also reduce or eliminate the time needed for response preparation before Task 2 response selection and hence reduce the PRP effect. We adopted the Task 2

used by Ruthruff et al. (2001; Experiment 2), which required participants to identify the letter *X* or *Y* and press one of two response keys. We assumed that this new Task 2 involved simpler mapping rules than old Task 2, which required participants to identify a character drawn from the set A, B, C, D, 1, 2, 3, 4 and press one of four response keys.

The new Task 2 used the same input and output modalities as the old Task 2 it replaced. However, there are two obvious differences between the old Task 2 and the new Task 2. First, the new Task 2 has far fewer stimulus-response pairings (two instead of eight). Second, the new Task 2 mapped letters onto the two response keys in alphabetic order, whereas the old Task 2 used an incompatible mapping for either the letters or the numbers (varied across participants for counterbalancing purposes). Because this new Task 2 response mapping was less complex, older adults might have been able to prepare for both Task 1 and Task 2 in advance of each trial in this experiment. Even if they could not fully prepare for Task 2 in advance, the time needed to switch to Task 2 after response selection on Task 1 should be greatly reduced. If so, the PRP effect for older adults in Experiment 3 should be reduced relative to that of Experiment 1.

Note that at this point participants had completed Experiment 2 (new Task 1-old Task 2 pairing). Therefore, to reinstate the learning from Experiment 1 (old Task 1-old Task 2), we retrained the participants on the tasks from that experiment for 80 dual-task trials before beginning Experiment 3.

### Method

#### Stimuli

The stimulus set for Task 1 was the same as in Experiment 1. The stimulus for Task 2 was letter *X* or *Y* presented in Times New Roman font. At a viewing distance of 46 cm, the characters subtended  $1.49^\circ$  vertically by  $1.04^\circ$  horizontally. Stimulus discriminability was varied by presenting the characters in either black (high-contrast condition) or gray (low-contrast condition) on a white background.

#### Procedure

Except for the introduction of a new Task 2 and where noted, the dual-task procedure was similar to that of Experiment 1. Participants responded to the character by pressing one of the two keys arranged horizontally on the response box using the fingers of the right hand. For all the participants, a keypress with the index finger was required for the letter *X* and a keypress with the middle finger for the letter *Y*.

Participants began with 32 practice trials on Task 1 only and 32 practice trials on Task 2 only. Then they performed 16 practice dual-task trials, which were followed by one block of 320 experimental dual-task trials.

### Results

The central results are comparisons between the late Blocks 6-7 of Experiment 1 and Experiment 3. Figure 7 shows the mean PRP effect, RT2, and RT1 in both age groups for Block 1 and for Blocks 6-7 of Experiment 1 and for Experiment 3. The RT2 and RT1 data come from the 1,000-ms SOA condition only.

Before analyzing the size of the PRP effect in both age groups, we first consider whether Task 1 performance was sensitive to further practice in each age group on the new dual-task pairing and

then compare the new Task 2 performance to the old Task 2 performance.

### RT1: Late Blocks of Experiment 1 Versus Experiment 3

The Age Group  $\times$  Experiment interaction was significant,  $F(1, 9) = 20.26, p < .01, MSE = 133.9, \eta^2 = .692$ . For younger adults, mean RT1 at the longest SOA was slightly longer in Blocks 6–7 of Experiment 1 ( $M = 310$  ms,  $SD = 38$  ms) than in Experiment 3 ( $M = 289$  ms,  $SD = 31$  ms); this difference was small and only marginally significant,  $F(1, 5) = 6.39, p = .05, MSE = 209.7, \eta^2 = .561$ , estimated power = .532. Thus, Task 1 learning transferred well despite being paired with a new Task 2. The small decrease in RT1 might reflect the slightly greater degree of practice on Task 1. For older adults, mean RT1 at the longest SOA was reduced by 66 ms from Blocks 6–7 ( $M = 495$  ms,  $SD = 86$  ms) to Experiment 3 ( $M = 429$  ms,  $SD = 85$  ms),  $F(1, 4) = 275.39, p < .01, MSE = 39.2, \eta^2 = .986$ . Thus, Task 1 learning transferred well for older adults as well. The decrease in RT1 might indicate that older adults had not reached an asymptotic level in baseline Task 1 performance late in practice and thus benefited from further Task 1 practice in Experiment 3 (as well as during the retraining block preceding this experiment).

### RT2: Late Blocks of Experiment 1 Versus Experiment 3

We assumed that the new Task 2 was both less complex and also less difficult than the old Task 2 and, therefore, that responses would be faster. To confirm this assumption, an ANOVA was carried out on RT2 at the longest SOA, with age group as a between-subjects variable and experiment (Blocks 6–7 of Experiment 1 and Experiment 3) as a within-subject variable. Consistent with this assumption, RT2 at the longest SOA was faster for the new Task 2 ( $M = 466$  ms,  $SD = 130$  ms) than for the old Task 2 ( $M = 663$  ms,  $SD = 190$  ms),  $F(1, 9) = 245.49, p < .01, MSE = 910.1, \eta^2 = .965$ . Moreover, the Age Group  $\times$  Experiment interaction was significant,  $F(1, 9) = 17.19, p < .01, MSE = 910.1, \eta^2 = .656$ . For younger adults, the mean RT for the new Task 2 ( $M = 369$  ms,  $SD = 45$  ms) was faster by 149 ms than the mean RT for the old Task 2 ( $M = 518$  ms,  $SD = 60$  ms); for older adults, the mean RT for the new Task 2 ( $M = 582$  ms,  $SD = 94$  ms) was faster by 256 ms than the mean RT for the old Task 2 ( $M = 838$  ms,  $SD = 129$  ms). In summary, even though the new Task 2 was not as highly practiced as the old Task 2, it still produced faster mean RT2 for both older and younger adults. These findings support our assumption that the new Task 2 is less difficult than the old Task 2 and arguably less complex.

### PRP Effect: Late Blocks of Experiment 1 Versus Experiment 3

The PRP effect was larger overall in older adults ( $M = 378$  ms,  $SD = 82$  ms) than in younger adults ( $M = 126$  ms,  $SD = 52$  ms),  $F(1, 9) = 38.38, p < .01, MSE = 9,018.2, \eta^2 = .810$ , and was larger overall in Blocks 6–7 of Experiment 1 ( $M = 260$  ms,  $SD = 172$  ms) than in Experiment 3 ( $M = 220$  ms,  $SD = 126$  ms),  $F(1, 9) = 8.92, p < .05, MSE = 1,230.6, \eta^2 = .498$ . The Age Group  $\times$  Experiment interaction was significant,  $F(1, 9) = 12.78, p < .01, MSE = 1,230.6, \eta^2 = .587$ . For younger adults, the PRP effect

remained unchanged from Blocks 6–7 of Experiment 1 ( $M = 121$  ms,  $SD = 59$  ms) to Experiment 3 ( $M = 130$  ms,  $SD = 55$  ms),  $F(1, 5) = 0.20, p = .67, MSE = 1,151.5, \eta^2 = .039$ . For older adults, the PRP effect declined significantly by 99 ms from Blocks 6–7 ( $M = 427$  ms,  $SD = 76$  ms) to Experiment 3 ( $M = 328$  ms,  $SD = 95$  ms),  $F(1, 4) = 18.27, p < .05, MSE = 1,329.3, \eta^2 = .820$ .

For younger adults, consistent with the B-SS model, similar RT1s in Blocks 6–7 of Experiment 1 and in Experiment 3 were accompanied by similar PRP effects. In addition, this result confirms that the size of the PRP effect did not depend on baseline Task 2 performance: The PRP effect in Experiment 3 was not facilitated by the introduction of a less complex new Task 2. If the PRP effect was independent of baseline Task 2 performance, the PRP effect in Experiment 3 should have been well predicted by the linear relation observed in Experiment 1 between the PRP effect and RT1 across blocks ( $PRP'_{\text{younger}} = .832 \times RT1 - 133.865, r^2 = .943$ ). Indeed, with the baseline Task 1 performance in Experiment 3 of 289 ms ( $SD = 31$  ms), the mean predicted PRP effect ( $M = 107$  ms,  $SD = 26$  ms) did not differ from the mean observed PRP effect ( $M = 130$  ms,  $SD = 55$  ms),  $t(5) = 0.88, p = .42$ .

For older adults, the decrease of 66 ms in baseline RT1 from Blocks 6–7 of Experiment 1 to Experiment 3 was accompanied by a decrease of 99 ms in the PRP effect. According to the B-SS model, assuming that Stage 2A was unchanged (see Equation 1), the PRP effect in Experiment 3 should have been well predicted by the linear relation observed in Experiment 1 between the PRP effect and RT1 across blocks ( $PRP'_{\text{older}} = .436 \times RT1 + 222.696, r^2 = .803$ ).<sup>5</sup> Contrary to this prediction, with a baseline Task 1 performance in Experiment 3 of 429 ms ( $SD = 85$  ms), the mean predicted PRP effect calculated from the regression line in Experiment 1 ( $M = 410$  ms,  $SD = 37$  ms) was significantly greater by 82 ms than the mean observed PRP effect ( $M = 328$  ms,  $SD = 95$  ms),  $t(4) = 2.74, p < .05$ . Therefore, for older adults, the 99-ms reduction in the PRP effect from Experiment 1 to Experiment 3 was not solely explained by a decrease in baseline RT1 but was in some way related to the introduction of a new, less complex Task 2.

### Task 1 RTs

An omnibus ANOVA was performed on RT1 observed in Experiment 3, with age group as a between-subjects variable and Task 1 difficulty, SOA, and Task 2 contrast as within-subjects variables. Mean RT1 was greater in older adults ( $M = 459$  ms,  $SD = 106$  ms) than in younger adults ( $M = 287$  ms,  $SD = 33$  ms),  $F(1, 9) = 14.27, p < .01, MSE = 112,813.3, \eta^2 = .613$ . No other effect was significant. In particular, RT1 remained unaffected by SOA,  $F(4, 36) = .46, p = .76, MSE = 2,041.5, \eta^2 = .162$ , estimated power = .439. In addition, the Age Group  $\times$  SOA interaction was not significant,  $F(4, 36) = 0.36, p = .84, MSE = 2,041.5, \eta^2 = .124$ , estimated power = .268.

<sup>5</sup> Because one older individual opted not to continue after Experiment 1, the equation relating PRP and RT1 across blocks of practice was slightly modified from the original one, which was  $PRP'_{\text{older}} = .484 \times RT1 + 176.672, r^2 = .863$ .

### *Task 1 and Task 2 Proportion Correct (T1 and T2 PC)*

We performed two ANOVAs, one on Task 1 proportion correct (T1 PC) and the other on Task 2 proportion correct (T2 PC), with age group as a between-subjects variable and SOA as a within-subject variable. In each analysis, there was neither a significant main effect nor a significant interaction. T1 PC were .93 and .95 for younger and older participants, respectively,  $F(1, 9) = 0.67$ ,  $p = .44$ ,  $\eta^2 = .069$ , estimated power = .114; and T2 PC were .94 and .97 for younger and older participants, respectively,  $F(1, 9) = 3.78$ ,  $p = .08$ ,  $\eta^2 = .296$ , estimated power = .412. Lack of power might have prevented the observation that older adults might be more accurate than younger adults on both Task 1 and Task 2.

### *Discussion*

The results of Experiment 3 demonstrated that introducing a new Task 2, assumed to require less preparation, reduced the PRP effect in older adults but not in younger adults relative to the late blocks of Experiment 1.

According to the B-SS model, the introduction of a new Task 2, faster than the old Task 2 that it replaced, should have had no effect on the PRP interference. In younger adults, the results confirmed this prediction: From Blocks 6–7 (old Task 1–old Task 2 pairing) to Experiment 3 (old Task 1–new Task 2 pairing), there was little change in mean RT1 and also little change in the size of the PRP effect. In addition, the linear relation observed in Experiment 1 between the PRP effect and RT1 across blocks predicted well the PRP effect observed in Experiment 3, thus confirming that PRP effects generally do not depend much on Task 2 complexity for younger adults.<sup>6</sup> In older adults, the decrease in baseline Task 1 performance with further practice was accompanied by a decrease in the PRP effect from the late blocks of Experiment 1 to Experiment 3. However, if the B-SS model holds in older adults, PRP effects should generally depend on RT1, not RT2. Contrary to this prediction, the linear relation observed in Experiment 1 between the PRP effect and RT1 across blocks did not predict the PRP effect observed in Experiment 3 as it should have if the PRP effect depended only on RT1 and not on RT2. Interestingly, the predicted PRP effect calculated from the regression line in Experiment 1 fell significantly above the observed PRP effect by 82 ms. Therefore, the PRP reduction in older adults from the late blocks of Experiment 1 to Experiment 3 was not solely due to the reduction in RT1. It must have been related to the introduction of a new, less complex Task 2. We presume that this new Task 2 reduced or even eliminated the time needed for response preparation subsequent to Task 1 response selection and before Task 2 response selection and thus reduced the PRP effect more than would be expected if there were no stage required for putting the response mappings in place. As in Experiment 2, these results are consistent with the hypothesis that, for older adults at least, there is a stage inserted into the Task 2 processing sequence before Task 2 response selection and that it requires more time when Task 1 is more complex (Experiment 1) but not when it is less complex (Experiment 3).

### *General Discussion*

The goal of this research was to determine how practice affects age-related differences in PRP interference. To answer this ques-

tion, 6 older adults and 6 younger adults practiced for seven blocks each in a PRP experiment in which Task 1 required a vocal response to a tone and Task 2 required a manual response to a character. The initial PRP effect was greater in older adults ( $M = 600$  ms) than in younger adults ( $M = 395$  ms), as previously reported by Allen et al. (1998), who also used the same input and output modalities on both Tasks 1 and 2. The results showed that six practice blocks allowed older adults to reach a PRP effect very similar ( $M = 390$  ms) to the one exhibited by younger adults during the first block of practice ( $M = 395$  ms). Thus, practice by older adults compensated for the initial age-related difference in the PRP effect. Most importantly, the PRP effect declined in both age groups across practice but more so in younger adults (274 ms vs. 192 ms for older adults) from Block 1 to Blocks 6–7. The analysis, which took into account the initial starting point (i.e., the PRP effect in Block 1), showed that practice reduced the size of the PRP effect far more in younger adults (69% reduction) than in older adults (32% reduction) relative to Block 1. Consequently, although practice reduced PRP interference in both younger and older adults, it actually increased the age-related difference in the PRP effect.

### *The Central Bottleneck Model Was Supported Both Early and Late in Practice in Both Younger and Older Adults*

The central bottleneck model of the PRP effect was supported by the pattern of experimental factor interactions with SOA early in practice in both age groups. In particular, we observed that (a) prolongation of processing in Task 1 up to and including the central stage (resulting from longer identification time of the intermediate tones relative to the extreme tones) carried over onto RT2 at short SOAs but not at long SOAs (i.e., the Task 1 carryover prediction); (b) prolongation of the early, prebottleneck stage in Task 2 (resulting from longer perception time of a low-contrast character relative to a high-contrast character) was smaller at short SOAs but not at long SOAs (i.e., the Task 2 absorption prediction); and (c) prolongation of central stage in Task 2 (resulting from longer time to map alphanumeric characters in a scrambled order onto response keys than to map characters in a compatible order onto the same keys) combined additively with decreasing SOA (i.e., the Task 2 additivity prediction). These results support the view that the PRP effects observed in both age groups early in practice were due to either an inability or a strategic decision not to perform central operations on more than one task at a time. Our results are consistent with previous reports in younger adults (for a review, see Lien & Proctor, 2002; Pashler, 1998; for a contrary view, see Meyer et al., 1995) and in older adults (Hartley & Little, 1999). Furthermore, the pattern of factor effects late in practice was still consistent with a central bottleneck model or a Task 2 processing lockout both in younger and older adults. The three key predictions from the central bottleneck model were verified in both age groups, except the Task 1 carryover prediction in younger

<sup>6</sup> Note that PRP effects are usually larger when the prebottleneck stages of Task 2 are especially short (see McCann & Johnston, 1992; Pashler & Johnston, 1989). This is unlikely to be the case here given that the new Task 2 and the old Task 2 share the same input modality; therefore, durations of the prebottleneck stages on both tasks could be expected to be similar.

adults, very likely because their Task 1 difficulty effects had become negligible at this point. The pattern of factor interactions late in practice in younger adults closely mimics the results of Van Selst et al. (1999), who used a similar dual-task pairing but roughly five times more dual-task practice blocks.

In summary, our results support the view that the PRP effects observed in younger and older adults throughout early to late in practice were due to a processing bottleneck, whether structural or strategic.

### *Why Practice Reduces the PRP Effect Less in Older Adults Relative to Younger Adults*

We first discuss explanations that could account for the overall reduction in the PRP effect across practice blocks (ignoring the differences between age groups) and then consider explanations that could account for the age-related difference in the reduction of the PRP effect across practice.

Van Selst et al. (1999) and Ruthruff et al. (2001) proposed two potential extensions of the central bottleneck model to account for the effects of practice in younger adults: the B-SS and the B-CSS models. Both models assume that practice does not eliminate the bottleneck. Instead, practice reduces the duration of processing stages. According to the B-SS model, practice is assumed to shorten the durations of central and noncentral stages. According to the B-CSS model, a more specific version of the B-SS model, practice is assumed to shorten only the duration of central stages. Empirically, the B-CSS model predicts a one-to-one relationship across practice between mean RT1 and the size of the PRP effect. The B-CSS model parsimoniously accounted for the Van Selst et al. data. Our results for younger adults closely resemble a weaker version of the B-CSS model, in which practice reduces primarily the duration of central stages and, to a lesser extent, the durations of noncentral stages.

The same model but with even greater reductions in certain noncentral stages (i.e., Stages 1C and 2A) would account for the results for older adults for whom the slope of the PRP-RT1 function fell significantly below that of younger adults. A 1-ms reduction in RT1 reduced the PRP effect by .83 ms in younger adults but only by about .48 ms in older adults. In this interpretation, practice appears to have had more global effects in older adults (shortening the durations of both central and noncentral stages) than in younger adults, for whom practice appeared to primarily shorten central stages.

If we assumed only that there exists an age-related slowing factor affecting all processing stages (cf. Hartley & Little, 1999), then the PRP-RT1 function for older adults should initially lie below that of younger adults. With practice, it should approach the PRP-RT1 function of younger adults without actually crossing over. This prediction holds if one accepts that older adults perform noncentral stages more slowly than younger adults, in particular Stages 1C and 2A. Indeed, the intercept of Equation 2 (i.e.,  $-1C - 2A$ ), smaller in older adults than in younger adults, will produce a smaller PRP effect in older adults than in younger adults for a similar RT1 in both age groups, preventing any crossing of the PRP-RT1 functions of older and younger adults. Contrary to this prediction, the PRP-RT1 function of older adults was well above that of younger adults. The B-SS model extended to the effects of practice and aging cannot explain this result.

To rescue it, we proposed to add a stage (requiring time  $S$ ) in the typical PRP equation, a stage that requires longer time or is present only for older adults (Equation 2). Thus, the PRP effect can be expressed as  $RT1 - 1C - 2A + S - SOA_{short}$  (Equation 3). The initial intercept of the PRP-RT1 function of Equation 2 (i.e.,  $-1C - 2A$ ) will be increased more by  $S$  for older adults (i.e., the intercept becomes  $-1C - 2A + S$ ). If  $S$  is greater for older adults than younger adults, it would explain the shifting of the PRP-RT1 function in older adults upward from that in younger adults.

### *The Nature of the Parameter Added to the PRP Equation*

First, we propose that the operations of putting in place (or instantiating) the response mapping rules for both tasks occur for any pair of tasks and at each degree of temporal overlap between tasks. For Task 1, we presume that they are instantiated before the start of the trial. We presume this is also done for Task 2, when the response mapping rules are undemanding relative to the available capacities or capabilities (similar to the argument made by De Jong, 1995). When the Task 2 mapping rules are complex or are highly confusable with those for Task 1, we presume that they are either instantiated after response selection in Task 1 is complete or partially instantiated before the outset of the trial, and the instantiation is completed only after Task 1 response selection. We assume that older adults either have a lower capacity for maintaining action-ready rules or that they take additional cautions to avoid confusion. This package of assumptions explains why the effects of the additional stage would not be seen at long SOAs, why it would be more evident in older adults than in younger adults, and why increasing the complexity of either or both tasks would exaggerate age differences.

To explore our interpretation, we paired a less complex new Task 1 with the Task 2 previously practiced (Experiment 2) and a less complex new Task 2 with the Task 1 previously practiced (Experiment 3). Consistent with our proposal that the effects of the additional stage would be seen primarily in older adults, the PRP effect declined in older adults but not in younger adults in Experiments 2 and 3.

The PRP procedure resembles one that has been explored in the literature on task switching. In the task-switching procedure, the individual must maintain two possible sets of operations that can be carried out on the stimuli (e.g., with single digits as stimuli, one operation might be to determine whether it is even or odd, whereas the other operation might be to determine whether it is greater than 5 or less than 5). The individual is given some way to determine which operations should be applied on a particular trial, either through (a) instructions (e.g., alternate between rules), (b) an advance cue, or (c) some aspect of the stimulus itself (e.g., if the number is red, then determine whether it is odd; if it is green, determine whether it is greater or less than 5). Studies of task switching commonly find that overall RTs are slower in blocks of trials with a mix of tasks than in those with only a single type of task and that this difference is larger in older adults (Kray & Lindenberger, 2000; Mayr, 2001; Meiran, Gotler, & Perlman, 2001). The slower responses when switching is necessary are thought to reflect the costs of maintaining two sets of stimulus-response mappings at the same time in working memory (Mayr, 2001). The proposal of an added response-mapping instantiation stage to the PRP equation, particularly for older adults, is consis-

tent with greater switching costs in older adults relative to younger adults. Similarly, Mayr (2001) proposed that the complexity of the relation between stimulus and response (and response overlap between tasks) is responsible in part for age-related differences in switch costs. Indeed, Hunt and Klein (2002) have shown that task-switching costs can be greatly diminished when stimulus–response mapping is simplified, and Bojko, Kramer, and Peterson (2004) have demonstrated that age-related differences in switch costs can also be reduced when this is done. These results are consistent with the proposal that in the context of PRP interference, the switching process is larger when the tasks are complex (i.e., Experiment 1) but smaller when one of the two tasks is less complex (i.e., Experiments 2 and 3). Although it is attractive to presume that PRP and task switching are drawing on the same underlying processes, there is a serious difficulty with the argument. Older adults show a noticeably greater cost for blocks of trials in which tasks are mixed compared with blocks with only a single task. However, when trial-by-trial switch costs are examined, age differences vanish (Meiran et al., 2001). Trials that call for the same task as on the preceding trial are responded to faster than those trials on which the task shifts from the preceding trial, but the difference is equivalent for older and younger adults. A trial-to-trial, or local, shift is much closer to the within-trial shifts required in the PRP procedure than is a global shift from mixed to single-task blocks, yet the age differences in task switching are found only in global costs. The analogy between PRP and task-switching procedures may be weaker than it appears.

At this point, it is tempting to propose that the response rule instantiation parameter is mutable in response to changes in task complexity but not in response to practice. Such a proposal would imply that people, especially older adults, are not able to reduce the time required to put response-mapping rules into place with extended practice, either by moving the operations forward to the beginning of the trial, getting it done more quickly, or automating some of its potential substages. Our data demonstrate that late in practice there was still evidence of an additional stage in the Task 2 processing sequence, although only for older adults. This stage was reduced or eliminated when one of the tasks was simplified. Using a task-switching procedure, Kramer, Hahn, and Gopher (1999) found that older adults were capable of learning to switch between tasks as effectively as younger adults in situations in which working memory load was low but were unable to benefit from practice to improve switch performance to levels exhibited by younger adults in which working memory load was high (see also Kray & Lindenberger, 2000). These results are consistent with the interpretation that in older adults the operations of putting task response rules into place might not be sensitive to the amount of practice, especially given the high memory load required by the dual-task situation used in Experiment 1 (i.e., 32 possible mappings of stimulus pairs to response pairs).

#### *Relation to the EPIC Architecture*

The EPIC architecture view of PRP interference proposes that there is no immutable structural central limitation (Meyer & Kieras, 1997a, 1997b, 1999; Meyer et al., 1995; Schumacher et al., 2001). Instead, PRP interference arises from (a) strategic postponement of some stages of one task while another task is under way, (b) incomplete conversion of declarative to procedural

knowledge (cf. Schumacher et al., 2001), or (c) peripheral conflicts in sensory or motor stages. The two tasks did not share the same input and output modalities in any of the three current experiments, so peripheral conflicts should have been minimized. Nevertheless, the participants were instructed to emphasize the speed of Task 1. These instructions were chosen deliberately to prevent any grouping of Task 1 and Task 2 responses at the shortest SOA (i.e., withholding the response to Task 1 until Task 2 processing is complete), which would greatly complicate the interpretation of the results (Allen et al., 1998; Pashler & Johnston, 1989). From the EPIC perspective, both younger and older adults might have adopted a cautious task-coordination strategy early in practice in response to these instructions. That is, they may have strategically waited to start or resume Task 2 processing until completion of Task 1 central processing. Thus, early in practice, the PRP effect might have reflected a strategic postponement rather than a structural central limitation. In this context, the larger drop of PRP interference across practice in younger adults than in older adults could be explained as a result of the adoption of a progressively more daring task-coordination strategy across practice in younger adults than in older adults. Younger adults, and to a lesser extent older adults, could start or resume Task 2 central stages while Task 1 central processing was under way. It should be noted, however, that the task instructions did not change across the three experiments. Hence, there was no particular reason for participants to have adopted a more daring task-coordination strategy across practice and for younger adults to be more likely to do so than older adults. Alternatively, older adults might have been slower than younger adults in converting declarative rules to procedural rules, resulting in a differential drop of the PRP effect across practice blocks. In summary, adaptive executive control models derived from the EPIC architecture can account for the data. In the EPIC context, it is not possible to determine whether a differential change with age was due to an age-related differential use of task-coordination strategy, an age-related differential learning in synthesizing declarative rules into procedural rules, or a combination.

Nonetheless, the introduction of a new Task 1 with the old Task 2 previously practiced (Experiment 2) as well as the introduction of a new Task 2 with the old Task 1 previously practiced (Experiment 3) did not modify the size of the PRP in younger adults. Because each of the new tasks was unfamiliar for the participants relative to the old practiced task it replaced, proponents of EPIC might have predicted the adoption of a cautious task-coordination strategy and, therefore, an increase in the PRP interference relative to the last blocks of practice in Experiment 1. Our data provided no support for this prediction. More surprisingly, these two transfer experiments demonstrated a reduction of the PRP effect in older adults, relative to the late blocks of practice in Experiment 1. This result would not be inconsistent with adaptive executive control models: It would be modeled as a lower value for the Task 2 unlocking latency. The models can accommodate the result, but they did not predict it. By contrast, our proposal provides a theoretically motivated account of the specific operations that would have resulted in greater improvement for older adults with less complex response mapping rules.

Although the goal of this study was not to reach a 0-ms PRP effect in younger and older adults, we acknowledge that the current three experiments do not conform closely to the criteria argued as

necessary for virtually perfect time sharing between two tasks by Meyer, Kieras, Schumacher, Fencsik, and Glass (2001). Rather, our intent was to determine the extent of reduction in PRP interference that was possible with the PRP procedures previously used in studies of aging and dual-task performance. We also acknowledge that our data can be explained by an EPIC architecture of some form. Nevertheless, we believe that the flexibility of the EPIC architecture makes it difficult to predict in which cases the participants, especially older adults, will adopt one or another task-coordination strategy. At the same time, we note that the current data are well predicted by bottleneck model theories extended to the effects of both practice and advancing age. It remains to be determined whether older adults can demonstrate the virtually perfect time sharing that is permitted by some adaptive executive control models but that is difficult to account for with central bottleneck models.

### References

- Allen, P. A., Hall, R. J., Druley, J. A., Smith, A. F., Sanders, R. E., & Murphy, M. D. (2001). How shared are age-related influences on cognitive and non-cognitive variables? *Psychology and Aging, 16*, 532–549.
- Allen, P. A., Lien, M.-C., Murphy, M. D., Sanders, R. E., Judge, K. S., & McCann, R. S. (2002). Age differences in overlapping-task performance: Evidence for efficient parallel processing in older adults. *Psychology and Aging, 17*, 505–519.
- Allen, P. A., Smith, A. F., Vires-Collins, H., & Sperry, S. (1998). The psychological refractory period: Evidence for attentional differences in time-sharing. *Psychology and Aging, 13*, 218–229.
- Baron, A., & Mattila, W. R. (1989). Response slowing of older adults: Effects of time-limit contingencies on single- and dual-task performances. *Psychology and Aging, 4*, 66–72.
- Bertelson, P., & Tisseyre, F. (1969). Refractory period of c-reactions. *Journal of Experimental Psychology, 79*, 122–128.
- Bojko, A., Kramer, A. F., & Peterson, M. S. (2004). Age equivalence in switch costs for prosaccade and antisaccade tasks. *Psychology and Aging, 19*, 226–234.
- Borger, R. (1963). The refractory period and serial choice reactions. *Quarterly Journal of Experimental Psychology, 15*, 1–12.
- Cerella, J. (1985). Information processing rates in the elderly. *Psychological Bulletin, 98*, 67–83.
- De Jong, R. (1993). Multiple bottlenecks in overlapping task performance. *Journal of Experimental Psychology: Human Perception and Performance, 19*, 965–989.
- De Jong, R. (1995). The role of preparation in overlapping-task performance. *Quarterly Journal of Experimental Psychology: Human Experimental Psychology, 48A*, 2–25.
- Dutta, A., & Walker, B. N. (1995, November). *Persistence of the PRP effect: Evaluating the central bottleneck model*. Poster presented at the meeting of the Psychonomic Society, Los Angeles, CA.
- Fisk, A. D., Fisher, D. L., & Rogers, W. A. (1992). General slowing alone cannot explain age-related search effects: Reply to Cerella (1991). *Journal of Experimental Psychology: General, 121*, 73–78.
- Fisk, A. D., & Rogers, W. A. (1991). Toward an understanding of age-related memory and visual search effects. *Journal of Experimental Psychology: General, 120*, 131–149.
- Fletcher, B. C., & Rabbitt, P. M. A. (1978). The changing pattern of perceptual analytic strategies and response selection with practice in a two-choice reaction time task. *Quarterly Journal of Experimental Psychology, 30*, 417–427.
- Glass, J. M., Schumacher, E. H., Lauber, E. J., Zurbriggen, E. L., Gmeindl, L., Kieras, D. E., & Meyer, D. E. (2000). Aging and the psychological refractory period: Task-coordination strategies in young and old adults. *Psychology and Aging, 15*, 571–595.
- Greenwood, P., & Parasuraman, R. (1991). Effects of aging on the speed and attentional cost of cognitive operations. *Developmental Neuropsychology, 7*, 421–434.
- Hartley, A. A. (1992). Attention. In F. I. M. Craik & T. A. Salthouse (Eds.), *The handbook of aging and cognition* (pp. 3–49). Hillsdale, NJ: Erlbaum.
- Hartley, A. A. (2001). Age differences in dual-task interference are localized to response generation processes. *Psychology and Aging, 16*, 47–54.
- Hartley, A. A., & Little, D. M. (1999). Age-related differences and similarities in dual-task interference. *Journal of Experimental Psychology: General, 128*, 417–450.
- Hazeltine, E., Teague, D., & Ivry, R. B. (2002). Simultaneous dual-task performance reveals parallel response selection. *Journal of Experimental Psychology: Human Perception and Performance, 28*, 527–545.
- Hunt, A. R., & Klein, R. M. (2002). Eliminating the cost of task set reconfiguration. *Memory and Cognition, 30*, 529–539.
- Karlin, L., & Kestenbaum, R. (1968). Effects of number of alternatives on the psychological refractory period. *Quarterly Journal of Experimental Psychology, 20*, 167–178.
- Kieley, J. (1991). *A meta-analysis and review of aging and divided attention*. Unpublished manuscript, Claremont Graduate School, Claremont, CA.
- Kramer, A. F., Hahn, S., & Gopher, D. (1999). Task coordination and aging: Explorations of executive control processes in the task switching paradigm. *Acta Psychologica, 101*, 339–378.
- Kramer, A. F., & Larish, J. (1996). Aging and dual-task performance. In W. R. Rogers, A. D. Fisk, & N. Walker (Eds.), *Aging and skilled performance* (pp. 83–112). Hillsdale, NJ: Erlbaum.
- Kramer, A. F., Larish, J., & Strayer, D. L. (1995). Training for attentional control in dual-task settings: A comparison of young and old adults. *Journal of Experimental Psychology: Applied, 1*, 50–76.
- Kramer, A. F., Larish, J. F., Weber, T. A., & Bardell, L. (1999). Training for executive control: Task coordination and aging. In D. Gopher & A. Koriati (Eds.), *Attention and performance XVII* (pp. 617–652). Cambridge, MA: MIT Press.
- Kray, J., & Lindenberger, U. (2000). Adult age differences in task switching. *Psychology and Aging, 15*, 126–147.
- Lien, M.-C., & Proctor, R. W. (2002). Stimulus-response compatibility and psychological refractory period effects: Implications for response selection. *Psychonomic Bulletin and Review, 9*, 212–238.
- Lien, M.-C., Schweickert, R., & Proctor, R. W. (2003). Task switching and response correspondence in the psychological refractory period paradigm. *Journal of Experimental Psychology: Human Perception and Performance, 29*, 692–712.
- Madden, D. J. (2001). Speed and timing of behavioral processes. In J. E. Birren & K. W. Schaie (Eds.), *Handbook of the psychology of aging* (5th ed., pp. 288–312). San Diego, CA: Academic Press.
- Mayr, U. (2001). Age differences in the selection of mental sets: The role of inhibition, stimulus ambiguity, and response-set overlap. *Psychology and Aging, 16*, 96–109.
- McCann, R. S., & Johnston, J. C. (1992). Locus of the single-channel bottleneck in dual-task interference. *Journal of Experimental Psychology: Human Perception and Performance, 18*, 471–484.
- McDowd, J. M. (1986). The effects of age and extended practice on divided attention performance. *Journal of Gerontology, 41*, 764–769.
- Meiran, N., Gotler, A., & Perlman, A. (2001). Old age is associated with a pattern of relatively intact and relatively impaired task-set switching abilities. *Journal of Gerontology: Psychological Sciences, 2*, P88–P102.
- Meyer, D. E., Glass, J. M., Mueller, S. T., Seymour, T. L., & Kieras, D. E. (2001). Executive-process interactive control: A unified computational theory for answering 20 questions (and more) about cognitive ageing. *European Journal of Cognitive Psychology, 13*, 123–164.

- Meyer, D. E., & Kieras, D. E. (1997a). A computational theory of executive cognitive processes and multiple-task performance: Part 1. Basic mechanisms. *Psychological Review*, *104*, 3–65.
- Meyer, D. E., & Kieras, D. E. (1997b). A computational theory of executive cognitive processes and multiple-task performance: Part 2. Accounts of psychological refractory-period phenomena. *Psychological Review*, *104*, 749–791.
- Meyer, D. E., & Kieras, D. W. (1999). Précis to a practical unified theory of cognition and action: Some lessons from EPIC computational models of human multiple-task performance. In D. Gopher & A. Koriat (Eds.), *Attention and performance XVII* (pp. 17–88). Cambridge, MA: MIT Press.
- Meyer, D. E., Kieras, D. E., Lauber, E., Schumacher, E., Glass, J., Zurbriggen, E., et al. (1995). Adaptive executive control: Flexible multiple-task performance without pervasive immutable response-selection bottlenecks. *Acta Psychologica*, *90*, 163–190.
- Meyer, D. E., Kieras, D. E., Schumacher, E. H., Fencsik, D., & Glass, J. M. (2001, November). *Prerequisites for virtually perfect time sharing in dual-task performance*. Paper presented at the meeting of the Psychonomic Society, Orlando, FL.
- Mowbray, G. H., & Rhoades, M. V. (1959). On the reduction of choice reaction times with practice. *The Quarterly Journal of Experimental Psychology*, *14*, 1–36.
- Pashler, H. (1984). Processing stages in overlapping tasks: Evidence for a central bottleneck. *Journal of Experimental Psychology: Human Perception and Performance*, *10*, 358–377.
- Pashler, H. (1994). Dual-task interference in simple tasks: Data and theory. *Psychological Bulletin*, *116*, 220–244.
- Pashler, H. (1998). *The psychology of attention*. Cambridge, MA: MIT Press.
- Pashler, H., & Baylis, G. (1991). Procedural learning: 1. Locus of practice effects in speeded choice tasks. *Journal of Experimental Psychology: Learning, Memory, and Cognition*, *17*, 20–32.
- Pashler, H., & Johnston, J. C. (1989). Chronometric evidence for central postponement in temporally overlapping tasks. *Quarterly Journal of Experimental Psychology*, *41A*, 19–45.
- Pashler, H., & Johnston, J. C. (1998). Attentional limitations in dual-task performance. In H. Pashler (Ed.), *Attention* (pp. 155–189). Hove, England: Psychology Press.
- Rogers, W. A., Bertus, E. L., & Gilbert, D. K. (1994). Dual-task assessment of age differences in automatic process development. *Psychology and Aging*, *9*, 398–413.
- Ruthruff, E., Johnston, J. C., & Van Selst, M. (2001). Why practice reduces dual-task interference. *Journal of Experimental Psychology: Human Perception and Performance*, *27*, 3–21.
- Ruthruff, E., Johnston, J. C., Van Selst, M., Whitsell, S., & Remington, R. (2003). Vanishing dual-task interference after practice: Has the bottleneck been eliminated or is it merely latent? *Journal of Experimental Psychology: Human Perception and Performance*, *29*, 280–289.
- Salthouse, T. A., & Somberg, B. L. (1982). Skilled performance: Effects of adult age and experience on elementary processes. *Journal of Experimental Psychology: General*, *2*, 176–207.
- Schneider, W., Eschman, A., & Zuccolotto, A. (2002). *E-Prime reference guide*. Pittsburgh, PA: Psychology Software Tools.
- Schumacher, E. H., Lauber, E. J., Glass, J. M., Zurbriggen, E. L., Gmeindl, L., Kieras, D. E., & Meyer, D. E. (1999). Concurrent response-selection processes in dual-task performance: Evidence for adaptive executive control of task scheduling. *Journal of Experimental Psychology: Human Perception and Performance*, *25*, 791–814.
- Schumacher, E. H., Seymour, T. L., Glass, J. M., Fencsik, D. E., Lauber, E. J., Kieras, D. E., & Meyer, D. E. (2001). Virtually perfect time sharing in dual-task performance: Uncorking the central cognitive bottleneck. *Psychological Science*, *12*, 101–108.
- Schweickert, R. (1978). A critical path generalization of the additive factor method. *Journal of Mathematical Psychology*, *18*, 105–139.
- Schweickert, R. (1980). Critical-path scheduling of mental processes in a dual task. *Science*, *209*, 704–706.
- Schweickert, R., & Townsend, J. T. (1989). A trichotomy: Interactions of factors prolonging sequential and concurrent processes in stochastic discrete (PERT) networks. *Journal of Mathematical Psychology*, *33*, 328–347.
- Sit, R. A., & Fisk, A. D. (1999). Age-related performance in a multiple-task environment. *Human Factors*, *41*, 26–34.
- Sliwinski, M., & Buschke, H. (1999). Cross-sectional and longitudinal relationships among age, cognition, and processing speed. *Psychology and Aging*, *14*, 18–33.
- Smith, M. C. (1969). The effect of varying information on the psychological refractory period. *Acta Psychologica*, *30*, 220–231.
- Telford, C. W. (1931). Refractory phase of voluntary and associative responses. *Journal of Experimental Psychology*, *14*, 1–35.
- Van Selst, M., Ruthruff, E., & Johnston, J. C. (1999). Can practice eliminate the psychological refractory period effect? *Journal of Experimental Psychology: Human Perception and Performance*, *25*, 1268–1283.
- Verhaeghen, P., Steitz, D. W., Sliwinski, M. J., & Cerella, J. (2003). Aging and dual task performance: A meta-analysis. *Psychology and Aging*, *18*, 443–460.
- Welford, A. T. (1952). The “psychological refractory period” and the timing of high-speed performance: A review and a theory. *British Journal of Psychology*, *43*, 2–19.
- Welford, A. T. (1976). *Skilled performance: Perceptual and motor skills*. Glenview, IL: Scott Foresman.

Received November 25, 2003

Revision received July 19, 2004

Accepted July 28, 2004 ■